



General Purpose Motion Control Couplings

- Sliding Disc (Oldham)
- Universal Lateral (Uni-Lat)
 - Backlash-free up to 10° turns
 - Can tolerate large misalignments
 - Slight damping characteristics
 - Flex-free mechanical action - non-progressive bearing loads
 - Non-magnetic (with special screws)
 - Electrically isolating
 - Low inertia

Uni-Lats are widely used for pulse generator drives while Oldhams are very popular for stepper driven positioning stages.

A unique property of Uni-Lats is resistance to axial motion. This makes them suitable for light push/pull duties and for anchoring axially unrestricted shafts.

Oldhams are 3-part couplings consisting of 2 hubs + 1 torque disc. The hubs determine the method of installation and shaft attachment, the discs determine the quality of motion.

The 4 hub styles and 2 disc materials that comprise the range are fully interchangeable within each of the 9 sizes available. To take advantage of this flexibility, hubs and discs are specified and supplied separately.

The discs are the sacrificial elements and are replaceable at low cost in the event of wear or breakage.



Lateral Offset Couplings



General Performance Criteria

Temperature Range

-20°F to +140°F (-20°C to +60°C)

Maximum Rotational Speed

3000 rev/min

- ① **Blind hubs:** Length of parallel bore ± 0.2 . Bores may terminate in 118° incl. angle or flat bottomed.
Thro' hubs: Max permissible hub penetration.

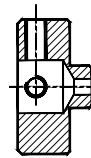

118° Included Angle

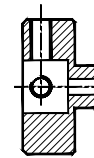

Flat Bottomed

- ② **Blind hubs:** Nominal distance between unchamfered shafts bottomed out to L1.
Thro' hubs: Nominal distance between shafts with standard (unbored) disc.
- ③ Maximum recommended tightening torque.
- ④ Values apply to complete couplings with max bores.
- ⑤ **Peak torque.** Select a size where Peak Torque exceeds the application torque x service factor.
- ⑥ Couplings can provide up to $(\text{ØD} \times 0.1)$ radial compensation in extreme cases.
 Observe given values for maximum backlash-free life.
 Axial compensation is set on installation.
 Electrical isolation between shafts > 3kV.
- ⑦ Values apply at 50% peak torque with no misalignment, measured shaft-to-shaft with largest standard bores.
- ⑧ Thro' hubs can be provided with keyways.

Blank hubs

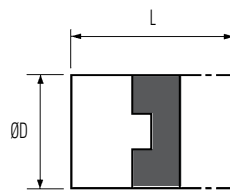

User-adaptable for special needs, e.g. fitting within tubes. Blank hubs are supplied centred with no provision for fastening. External dimensions identical with blind hubs.

Coupling size	Complete hub ref.	ØD	L
06	231.06.00	0.25 (6.4)	0.50 (12.7)
09	231.09.00	0.37 (9.5)	0.50 (12.7)
13	231.13.00	0.50 (12.7)	0.63 (15.9)
19	231.19.00	0.75 (19.1)	0.87 (22.0)
25	231.25.00	1.00 (25.4)	1.12 (28.4)
33	231.33.00	1.31 (33.3)	1.65 (42.0)
41	231.41.00	1.63 (41.3)	2.00 (50.8)

Standard discs (larger sizes are webbed)



- Acetal – High torsional stiffness, good bearing properties, long backlash-free life.
- Nylon 11 – Resilient, isolates noise & vibration. Performance approximately 25% that of acetal disc.

Thro' bored discs



Thro' bored discs allow shafts to near-butt, standard thro' hole diameter = $\text{ØD} \times 0.5$. To order, add suffix 'T' to order code, eg., **236.25T**. Other thro' hole diameters are manufactured to order. Specify the disc ref. and thro' hole diameter. This should equal the larger shaft diameter + 2 x max radial error.

Note that thro' bored discs reduce torsional stiffness.

Brass / Aluminium Blind Hubs

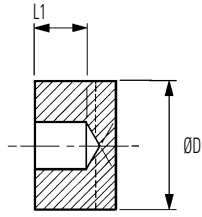

Controlled bore depth L1 provides a register when pre-assembling hubs to shafts

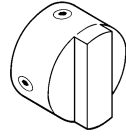

Set screw style



Clamp style

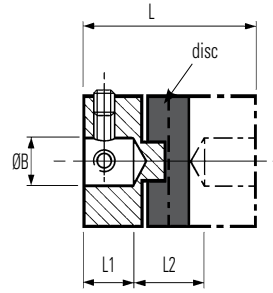

Refs. 232
Set screw style

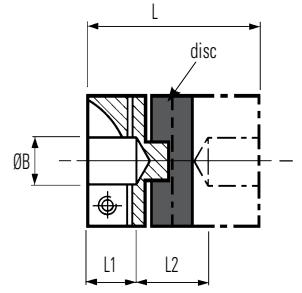

Refs. 234
Clamp style

DIMENSIONS & ORDER CODES

Coupling Type and Size	Hub Ref		Dimensions								Fasteners			Disc Ref	
	Set Screw Style	Clamp Style	ØD in. (mm)	L in. (mm)	① L1 in. (mm)	② L2 in. (mm)	ØB1 Max in. (mm)	④ Moment of Inertia kgm ² x10 ⁻⁸	④ Mass kg x10 ⁻³	Size	③ Torque lb.-in (Nm)	Wrench in. (mm)	Acetal (black) Std.	Nylon 11 (Natural)	
Blind Hubs	06	232.06	-	.25 (6.4)	0.5 (12.7)	0.15 (3.8)	0.20 (5.1)	0.13 (3.18)	6	2.5	M3	8.32 (0.94)	0.06 (1.5)	236.06	238.06
	09	232.09	-	.37 (9.50)	0.5 (12.7)	0.15 (3.8)	0.20 (5.1)	0.20 (5)	18	4	M3	8.32 (0.94)	0.06 (1.5)	236.09	238.09
	13	232.13	-	0.5 (12.7)	0.63 (15.9)	0.17 (4.3)	0.29 (7.3)	0.25 (6.35)	26	11	M3	8.32 (0.94)	0.06 (1.5)	236.13	238.13
	19	232.19	-	.75 (19.1)	0.87 (22.0)	0.25 (6.3)	0.37 (9.4)	0.31 (8)	67	12	M3	8.32 (0.94)	0.06 (1.5)	236.19	238.19
		-	234.19								M2.5	11.6 (1.32)	0.08 (2.0)		
	25	232.25	-	1.0 (25.4)	1.12 (28.4)	0.34 (8.6)	0.44 (11.2)	0.47 (12)	252	31	M4	20.1 (2.27)	0.08 (2.0)	236.25	238.25
		-	234.25								M3	21.5 (2.43)	0.10 (2.5)		
	33	232.33	-	1.31 (3.3)	1.65 (42.0)	0.51 (13.0)	0.63 (16.0)	0.63 (16)	1074	72	M5	40.9 (4.62)	0.06 (1.5)	836.33	838.33
	-	234.33								M4	20.6 (2.33)	0.08 (2.0)			
41	232.41	-	1.62 (41.3)	2.0 (50.8)	0.66 (16.7)	0.69 (17.4)	0.79 (20)	3327	148	M5	40.1 (4.62)	0.10 (2.5)	236.41	238.41	
	-	234.41								M4	50.1 (5.66)	0.12 (3.0)			

PERFORMANCE (AT 20°C WITH STANDARD ACETAL DISC)

Coupling Size	⑤ Peak torque lbs.-in. (Nm)	⑥ Max compensation @ 3000 rpm			⑦ Torsional		Static break torque lbs.-in. (Nm)
		Angular deg	Radial in. (mm)	Axial in. (± mm)	Rate deg / Nm	Stiffness Nm / rad	
06	0.53 (0.06)	0.5	.004 (0.1)	.002 (0.05)	5.7	10	6.2 (0.7)
09	1.90n (0.21)		.004 (0.1)	.002 (0.05)	1.9	30	17.8 (2)
13	4.43 (0.5)		.004 (0.1)	.002 (0.05)	0.88	65	35.4 (4)
19	15.0 (1.7)		.008 (0.2)	.004 (0.1)	0.50	115	70.1 (8)
25	35.4 (4)		.008 (0.2)	.004 (0.1)	0.28	205	115 (13)
33	79.7 (9)		.008 (0.2)	.006 (0.15)	0.093	615	469 (53)
41	151 (17)		.01 (0.25)	.006 (0.15)	0.048	1200	504 (57)

Materials & Finishes

Hubs sizes 06 to 13 : Brass Cu Zn 21 Si 3P [Lead Free]

Hub sizes 19 to 41: Al Alloy 2014 16

Fasteners: Alloy steel, black oiled

Aluminum hubs: Irridite NCP finish

IMPORTANT

Load capacity depends on application conditions:
see page 4 for details

STANDARD BORES FOR ALL TYPES

Sizes indicated in parenthesis are metric (mm).

Coupling Size	ØB1, ØB2 +0.0012/ -0 (+0.03mm/-0mm)																							
	(2)	(3)	1/8" (4)	3/16" (5)	(6)	1/4" (8)	3/8" (10)	(12)	1/2" (14)	(15)	5/8" (16)	(18)	(19)	3/4" (20)	(24)	(25)	(30)							
06	•	•	•																					
09		•	•	•	•																			
13		•	•	•	•	•																		
19			•	•	•	•	•																	
25					•	•	•	•																
33							•	•	•	•	•	•	•	•										
41								•	•	•	•	•	•	•	•	•	•							
Bore ref.	11	14	16	18	19	20	22	24	28	31	32	35	36	38	40	41	42	45	46	47	48	51	52	56

Aluminium Thro' Hubs

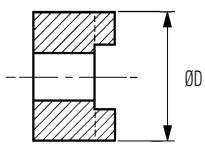

Thro' bores allow disc replacement without disturbing shaft alignment

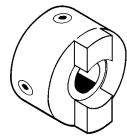

Set screw style

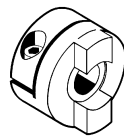

Clamp style

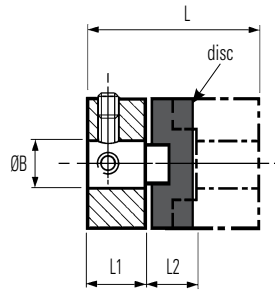

Refs. 450
Set screw style

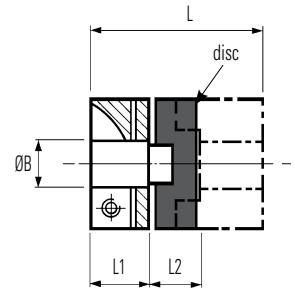

Refs. 452
Clamp style

DIMENSIONS & ORDER CODES

Coupling Type and Size	Hub Ref		Dimensions								Fasteners			Disc Ref	
	Set Screw Style	Clamp Style	ØD in. (mm)	L in. (mm)	① L1 in. (mm)	② L2 in. (mm)	ØB1 Max in. (mm)	④ Moment of Inertia kgm ² x10 ⁻⁸	④ Mass kg x10 ⁻³	Size	③ Torque lb.-in. (Nm)	Wrench in. (mm)	Acetal (black) Std.	Nylon 11 (Natural)	
Thro' Hubs	13	450H13	-	0.5 (12.7)	0.63 (15.9)	0.21 (5.5)	0.08 (1.7)	0.25 (6.35)	20	10	M3	8.32 (0.94)	0.06 (1.5)	236.13	238.13
	19	450H19	-	.75 (19.1)	1.02 (26.0)	0.37 (9.4)	0.28 (7.2)	0.31 (8)	59	13	M4	20 (2.27)	0.08 (2.0)	236.19	238.19
		-	452H19								M2.5	11.6 (1.32)	0.08 (2.0)		
	25	450H25	-	1.0 (25.4)	1.28 (32.4)	0.46 (11.6)	0.36 (9.2)	0.47 (12)	252	31	M5	40.9 (4.62)	0.10 (2.5)	236.25	238.25
		-	452H25								M3	21.5 (2.43)	0.10 (2.5)		
	33	450H33	-	1.31 (33.3)	1.65 (42.0)	0.59 (15.0)	0.47 (12.0)	0.63 (16)	1080	67	M6	67.4 (7.61)	0.12 (3.0)	836.33	838.33
		-	452H33								M4	50.1 (5.66)	0.12 (3.0)		
	41	450H41	-	1.62 (41.3)	2.0 (50.8)	0.70 (17.8)	0.60 (15.3)	0.79 (20)	3177	142	M6	67.4 (7.61)	0.12 (3.0)	236.41	238.41
		-	452H41								M4	50.1 (5.66)	0.12 (3.0)		
50	450H50	-	1.97 (50.0)	2.35 (59.6)	0.81 (20.6)	0.72 (18.4)	1.0 (25.4)	7550	208	M8	162 (18.36)	0.16 (4.0)	236.50	-	
	-	452H50								M5	101 (11.40)	0.16 (4.0)			
57	450H57	-	2.25 (57.1)	3.07 (78.0)	1.12 (28.4)	0.83 (21.2)	1.18 (30)	12410	361	M8	162 (18.36)	0.16 (4.0)	236.57	-	
	-	452H57								M6	171 (19.34)	0.20 (5.0)			

PERFORMANCE (AT 20°C WITH STANDARD ACETAL DISC)

Coupling Size	⑤ Peak torque lbs.-in. (Nm)	⑥ Max compensation @ 3000 rpm			⑦ Torsional		Static break torque lbs.-in. (Nm)
		Angular deg	Radial in. (mm)	Axial in. (± mm)	Rate deg / Nm	Stiffness Nm / rad	
13	4.43 (0.5)	0.5	.004 (0.1)	.002 (0.05)	0.88	65	35.4 (4)
19	15.0 (1.7)		.008 (0.2)	.004 (0.1)	0.50	115	70.1 (8)
25	35.4 (4)		.008 (0.2)	.004 (0.1)	0.28	205	115 (13)
33	79.7 (9)		.008 (0.2)	.006 (0.15)	0.093	615	469 (53)
41	151 (17)		.01 (0.25)	.006 (0.15)	0.048	1200	504 (57)
50	266 (30)		.01 (0.25)	.008 (0.2)	0.042	1375	841 (95)
57	389 (44)		.01 (0.25)	.008 (0.2)	0.022	2610	1328 (150)

Materials Finishes

- Hub sizes 13 to 57 : Al Alloy 2014A 16
- Fasteners: Alloy steel, black oiled
- Hubs: Clear anodised finish

IMPORTANT

Load capacity depends on application conditions:
see page 4 for details

STANDARD BORES® FOR ALL TYPES

Sizes indicated in parenthesis are metric (mm).

Coupling Size	ØB1, ØB2 +0.0012/ -0 (+0.03mm/-0mm)																								
	(2)	(3)	1/8"	(4)	3/16"	(5)	(6)	1/4"	(8)	3/8"	(10)	(12)	1/2"	(14)	(15)	5/8"	(16)	(18)	(19)	3/4"	(20)	(24)	(25)	(30)	
13		•	•	•	•	•	•	•																	
19				•	•	•	•	•																	
25						•	•	•																	
33							•	•	•	•	•	•	•	•	•	•	•								
41								•	•	•	•	•	•	•	•	•	•	•	•	•	•	•	•	•	•
50									•	•	•	•	•	•	•	•	•	•	•	•	•	•	•	•	•
57										•	•	•	•	•	•	•	•	•	•	•	•	•	•	•	•
Bore ref.	11	14	16	18	19	20	22	24	28	31	32	35	36	38	40	41	42	45	46	47	48	51	52	56	

Stainless Steel Thro' Hubs

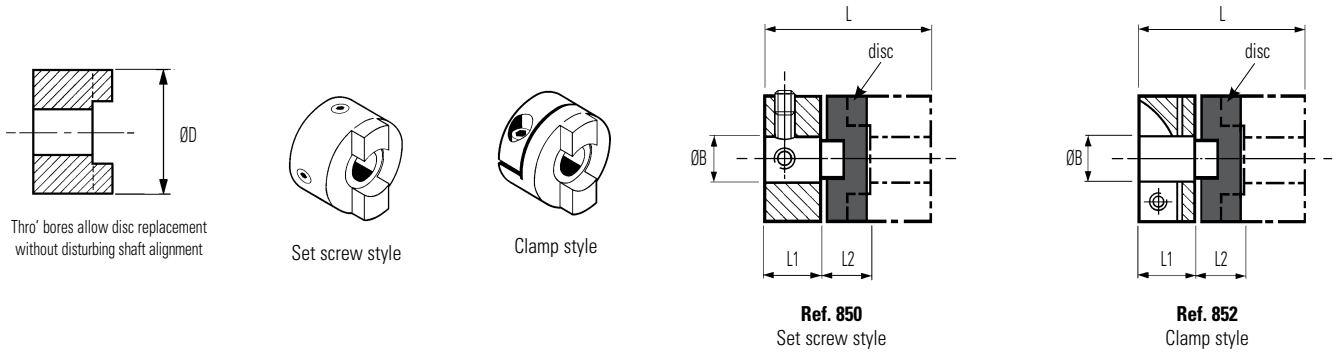

DIMENSIONS & ORDER CODES

Size	Hub Ref		Dimensions							Fasteners			Disc Ref	
	Set Screw Style	Clamp Style	ØD in. (mm)	L in. (mm)	L1 in. (mm)	L2 in. (mm)	ØB1 Max in. (mm)	Moment of Inertia kgm ² x10 ⁻⁸	Mass kg x10 ⁻³	Size	Torque lbs.-in. (Nm)	A/F in. (mm)	Acetal (black) Std.	Nylon 11 (Nat)
13	850.13	-	0.5 (12.7)	0.63 (15.9)	0.21 (5.5)	0.08 (1.7)	0.25 (6.35)	26	14	M3	2.83 (0.32)	0.06 (1.5)	236.13	238.13
19	850.19	-	0.75 (19.1)	1.02 (26.0)	0.37 (9.4)	0.28 (7.2)	0.31 (8.0)	220	45	M4	9.3 (1.05)	0.08 (2.0)	236.19	238.19
	-	852.19								M2.5	6.0 (0.68)	0.08 (2.0)		
25	850.25	-	1.0 (25.4)	1.28 (32.4)	0.46 (11.6)	0.36 (9.2)	0.47 (12.0)	587	76	M5	18.6 (2.1)	0.10 (2.5)	236.25	238.25
	-	852.25								M3	10.6 (1.2)	0.10 (2.5)		
33	850.33	-	1.31 (33.3)	1.65 (42.0)	0.60 (15.0)	0.36 (12.0)	0.63 (16.0)	2091	165	M6	33.6 (3.8)	0.12 (3.0)	836.33	838.33
	-	852.33								M4	25.7 (2.9)	0.12 (3.0)		
41	850.41	-	1.63 (41.3)	2.0 (50.8)	0.70 (17.8)	0.6 (15.3)	0.79 (20.0)	6822	305	M6	33.6 (3.8)	0.12 (3.0)	236.41	238.41
	-	852.41								M5	52.2 (5.9)	0.16 (4.0)		
50	850.50	-	1.97 (50.0)	2.35 (59.6)	0.81 (20.6)	0.81 (20.6)	1.0 (25.4)	17368	510	M8	79.7 (9.0)	0.16 (4.0)	236.50	N/A
	-	852.50								M6	86.7 (9.8)	0.20 (5.0)		

PERFORMANCE (AT 20°C WITH STANDARD ACETAL DISC)

Coupling Size	⑤ Peak torque lbs.-in. (Nm)	⑥ Max compensation @ 3000 rpm			⑦ Torsional		Static break torque lbs.-in. (Nm)
		Angular deg	Radial in. (mm)	Axial in. (± mm)	Rate deg / Nm	Stiffness Nm / rad	
13	4.43 (0.5)	0.5	.004 (0.1)	.002 (0.05)	0.88	65	35.4 (4)
19	15.0 (1.7)		.008 (0.2)	.004 (0.1)	0.50	115	70.1 (8)
25	35.4 (4)		.008 (0.2)	.004 (0.1)	0.28	205	115 (13)
33	79.7 (9)		.008 (0.2)	.006 (0.15)	0.093	615	469 (53)
41	151 (17)		.01 (0.25)	.006 (0.15)	0.048	1200	504 (57)
50	266 (30)		.01 (0.25)	.008 (0.2)	0.042	1375	841 (95)

Materials Finishes

Hubs: Stainless Steel 303 S31
- Natural Finish

Fasteners: Stainless Steel

IMPORTANT

Load capacity depends on application conditions:
see page 4 for details

STANDARD BORES® FOR ALL TYPES

Sizes indicated in parenthesis are metric (mm).

Coupling Size	ØB1, ØB2 +0.0012/ -0 (+0.03mm/-0mm)																								
	(2)	(3)	1/8"	(4)	3/16"	(5)	(6)	1/4"	(8)	3/8"	(10)	(12)	1/2"	(14)	(15)	5/8"	(16)	(18)	(19)	3/4"	(20)	(24)	(25)	(30)	
13		•	•	•	•	•	•	•																	
19				•	•	•	•	•																	
25						•	•	•	•	•	•	•													
33							•	•	•	•	•	•	•	•	•	•	•								
41									•	•	•	•	•	•	•	•	•	•	•	•	•	•	•	•	•
50										•	•	•	•	•	•	•	•	•	•	•	•	•	•	•	•
Bore ref.	11	14	16	18	19	20	22	24	28	31	32	35	36	38	40	41	42	45	46	47	48	51	52	56	

Universal / Lateral Offset Couplings



Materials & Finishes

- Hub sizes 18 & 27:** Brass BS CZ121
- Hub sizes 34, 41 & 70:** Al. Alloy 2014 T6
Irridite NCP
- Fasteners:** Alloy steel, black oiled
- Clamp rings (sizes 18 & 27):** Al. Alloy 2014 T6
Irridite NCP
- Torque rings, all sizes:** Acetal (black)

Temperature Range

-20°F to +140°F (-20°C to +60°C)

Set screw hubs

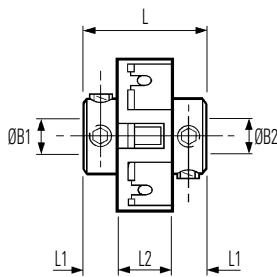

Ref. 201
Small bores

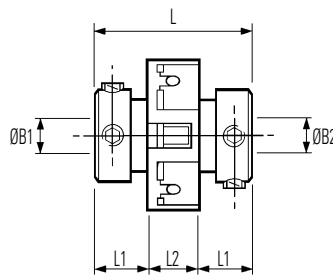

Ref. 203
Large bores

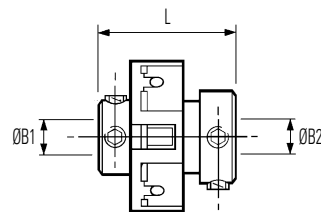

Ref. 221 (not listed in main table).
Combines large & small bores.
See explanatory note on facing page

Coupling ref. 221	
Size	L in. (mm)
18	0.66 (16.7)
27	0.88 (22.3)
34	1.10 (28.0)
41	1.31 (33.3)

Clamp hubs

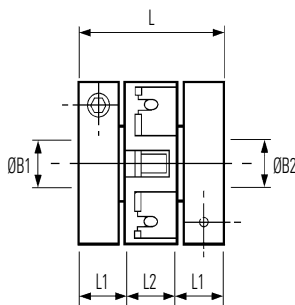

Ref. 207
Collet hub & ring clamp

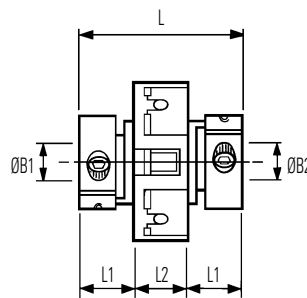

Ref. 205
Integral leaf clamp

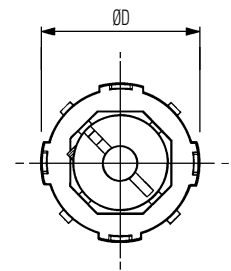

Typical

Installation

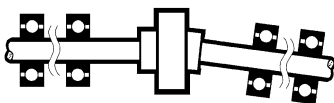

right

Up to 10° angular offset,
depending on type

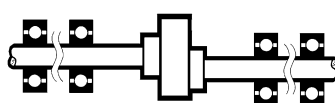

right

Up to 1mm radial offset for
extreme misalignments

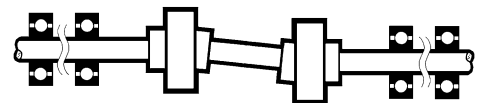

wrong

Standard Uni-Lats cannot be used in pairs.
Special versions are available for use in this mode.
Please enquire.

Universal / Lateral Offset Couplings

DIMENSIONS & ORDER CODES

Coupling Size	Set Screw Hubs	Clamp Hubs	ØD in. (mm)	L in. (mm)	① L1 in. (mm)	② L2 in. (mm)	ØB1, ØB2 max in. (mm)	Fasteners			④ Moment of inertia kgm ² x 10 ⁻⁸	④ Mass kg x 10 ⁻³
								Screw	③ Torque lb.-in. (Nm)	Wrench in. (mm)		
COUPLING REF												
18	201.18	–	.71 (18.0)	.56 (14.2)	.18 (4.6)	0.20 (5.1)	0.20 (5)	M3	8.32 (0.94)	0.06 (1.5)	20	7
	203.18	–	.75 (19.1)	.28 (7.0)	0.25 (6.35)							
	–	207.18 ‡ 218	–	0.75 (19.1)			M2.5	11.6 (1.32)	0.08 (2.0)	55	11	
27	201.27	–	1.10 (28.0)	.75 (19.1)	0.24 (6.1)	0.27 (6.9)	0.31 (8)	M3	8.32 (0.94)	0.06 (1.5)	91	16
	203.27	–	1.0 (25.4)	0.37 (9.3)	0.39 (10)							
	–	207.27 ‡ 218	–				M3	21.5 (2.43)	0.10 (2.5)	220	26	
34	201.34	–	1.33 (33.7)	.99 (25.2)	0.32 (8.1)	0.35 (8.9)	0.38 (10)	M4	20.1 (2.27)	.08 (2.0)	165	17
	203.34	–	1.21 (30.7)	0.43 (10.9)	0.5 (12.7)							
	–	205.34	–				M2.5	11.6 (1.32)		183	20	
41	201.41	–	1.63 (41.4)	1.12 (28.4)	0.34 (8.6)	0.44 (11.2)	0.5 (12.7)	M4	20.1 (2.27)	.08 (2.0)	476	30
	203.41	–	1.5 (38.1)	0.53 (13.5)	0.63 (16)							
	–	205.41	–				M4	50.1 (5.66)	0.12 (3.0)	550	40	
70	203.70	–	1.14 (69.0)	2.91 (74.0)	1.12 (28.5)	0.67 (17.0)	0.87 (22)	M6	67 (7.60)	0.12 (3.0)	7315	189
	–	205.70	–									

- ① Length of supported thro' bore. Shafts must not penetrate beyond L1 when in operation.
- ② Nominal distance between shafts inserted to L1.
- ③ Maximum recommended tightening torque.
- ④ Values apply with max bores.
- ⑤ Peak torque. Select a size where Peak Torque exceeds the application torque x service factor. (see page 4)
- ⑥ Couplings can provide up to 1mm radial and 10° angular compensation (5° for ref. 207) when required. Observe given values for maximum backlash-free life. Electrical isolation between shafts > 3kV for all models when offset ≤5°.
- ⑦ Values apply at 50% peak torque with no misalignment, measured shaft-to-shaft with largest standard bores.

‡ Ref. 207 only. Insert both bore codes in place of ‡.

PERFORMANCE AT 20°C

Coupling Size	⑤ Peak torque lb.-in. (Nm)	⑥ Max compensation @ 3000 rpm		⑦ Torsional		Axial		Static break torque lb.-in. (Nm)
		Angular deg	Radial in. (mm)	Rate deg / Nm	Stiffness Nm / rad	Max loading ±N	Stiffness N / mm	
18	2.66 (0.3)	2	.008 (0.2)	2.3	25	19	155	7.97 (0.9)
27	15.1 (1.7)		.008 (0.2)	0.6	92	31	350	44.3 (5.0)
34	22.1 (2.5)		.010 (0.25)	0.4	146	34	300	66.4 (7.5)
41	31.0 (3.5)		.010 (0.25)	0.19	299	39	250	92.9 (10.5)
70	106 (12.0)		.010 (0.25)	0.19	1300	75	540	602 (68)

Coupling ref. 221

By specifying ref. 221 (not listed in tables, see diagram previous page) you can combine the bores coded for ref. 201 with those coded for ref. 203,

eg., 221.27.2432 specifies Size 27 with Ø6.35 x 10 bores.

IMPORTANT

Load capacity depends on application conditions: **see page 4** for details

STANDARD BORES

Sizes indicated in parenthesis are metric (mm).

Coupling size	ref.	ØB1, ØB2 +0.0012/ -0 (+0.03mm/-0mm)																			
		(3)	1/8"	(4)	3/16"	(5)	(6)	1/4"	5/16"	(8)	3/8"	(10)	(12)	1/2"	(14)	5/8"	(16)	(18)	(19)	3/4"	(18)
18	201.18	•	•	•	•	•															
	203.18						•	•													
	207.18	•	•	•	•	•	•	•													
27	201.27	•	•	•	•	•	•	•	•												
	203.27									•	•										
	207.27					•	•	•		•	•	•									
34	201.34						•	•		•	•	•									
	203.34												•	•							
	205.34						•	•	•	•	•	•									
41	201.41						•	•		•	•	•	•								
	203.41														•	•	•				
	205.41						•	•		•	•	•	•								
70	203.70												•	•	•	•	•	•	•	•	•
	205.70												•	•	•	•	•	•	•	•	•
Bore ref.		14	16	18	19	20	22	24	27	28	31	32	35	36	38	41	42	45	46	47	48
Corresponding bore adaptor						251		253		254* 255		257		259			260				261

Diameters for which a bore adaptor is shown can be adapted to smaller shaft sizes. See page 58 for details.

*Note that adaptor 254 is dedicated to coupling ref. 201.27. Use adaptor 255 for all other 8mm diameters.