

HAHN LOCKING GAS SPRINGS

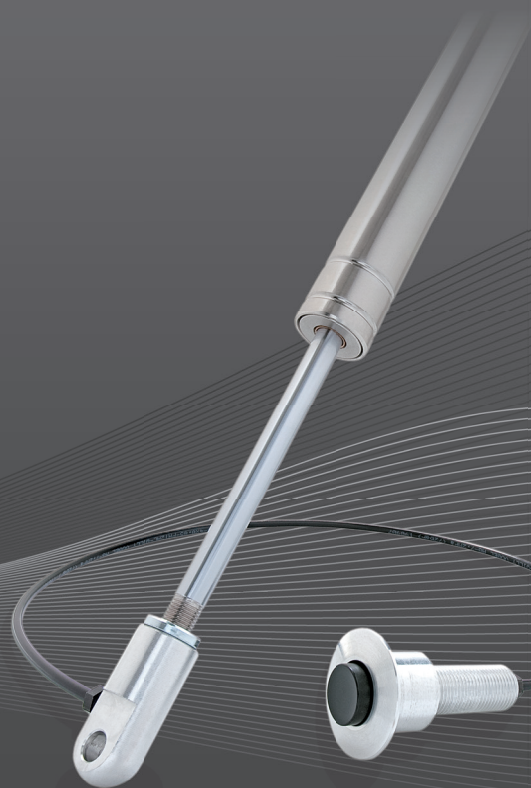

© HAHN Gasfedern GmbH

The catalogue is subject to technical alterations and printing mistakes / BGF.EN 10/2016

HAHN Gasfedern GmbH

Waldstrasse 39–43, 73773 Aichwald, Germany

Fon +49(0) 711 936 705-0 | Fax -40

info@hahn-gasfedern.com | www.hahn-gasfedern.com



Made in Germany

www.hahn-gasfedern.com

HAHN LOCKING GAS SPRINGS

cross-sectional view

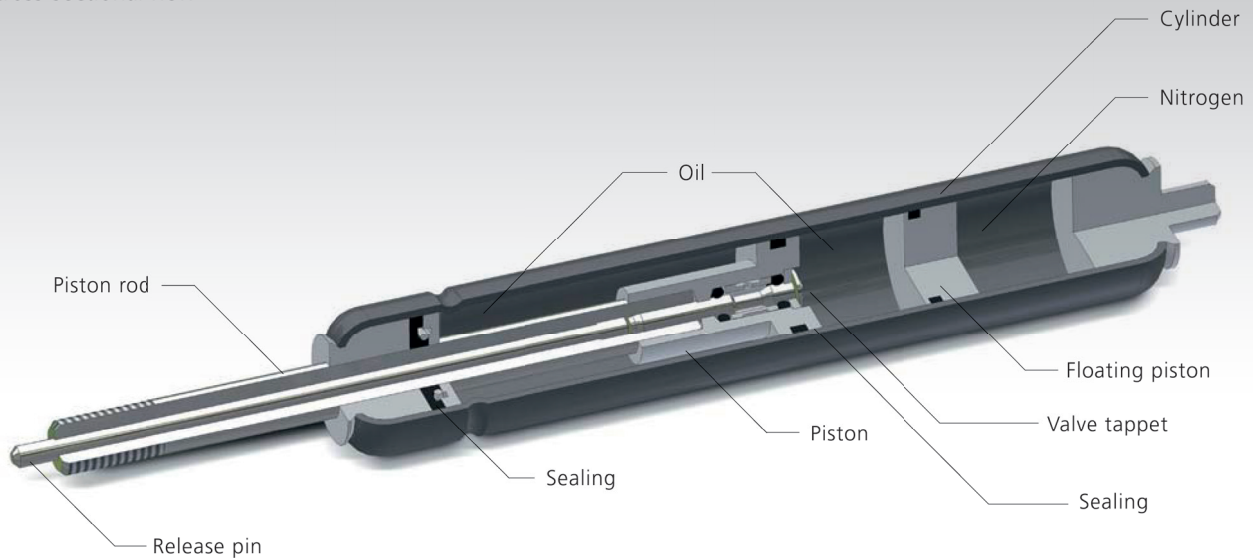

HAHN locking gas springs can be locked steplessly along the complete stroke. Furniture, vehicle seats, flaps, etc. can be locked in the desired position and readjusted.

When the release is actuated, the piston valve opens. In the elastic locking gas springs it is nitrogen, in the rigid locking gas springs it is oil that flows through the piston. The piston rod can only be moved, when the valve is opened. By releasing the trigger, the valve closes immediately and the piston rod is locked in the desired position.

HAHN Gasfedern adjusts the locking type exactly to the specific needs. The customers can choose between elastic locking, rigid locking, absolutely rigid locking, free-moving locking and locking in both directions. HAHN locking gas springs are available in steel, in AISI 303/304 and in AISI 316L/316Ti.

The HAHN Release System is especially made and adapted for your applications and requests.

We offer a wide range of release systems for all HAHN locking gas springs. Depending of the application, the springs can be released either with a lever release, a bowden wire release or a hydraulic release.