

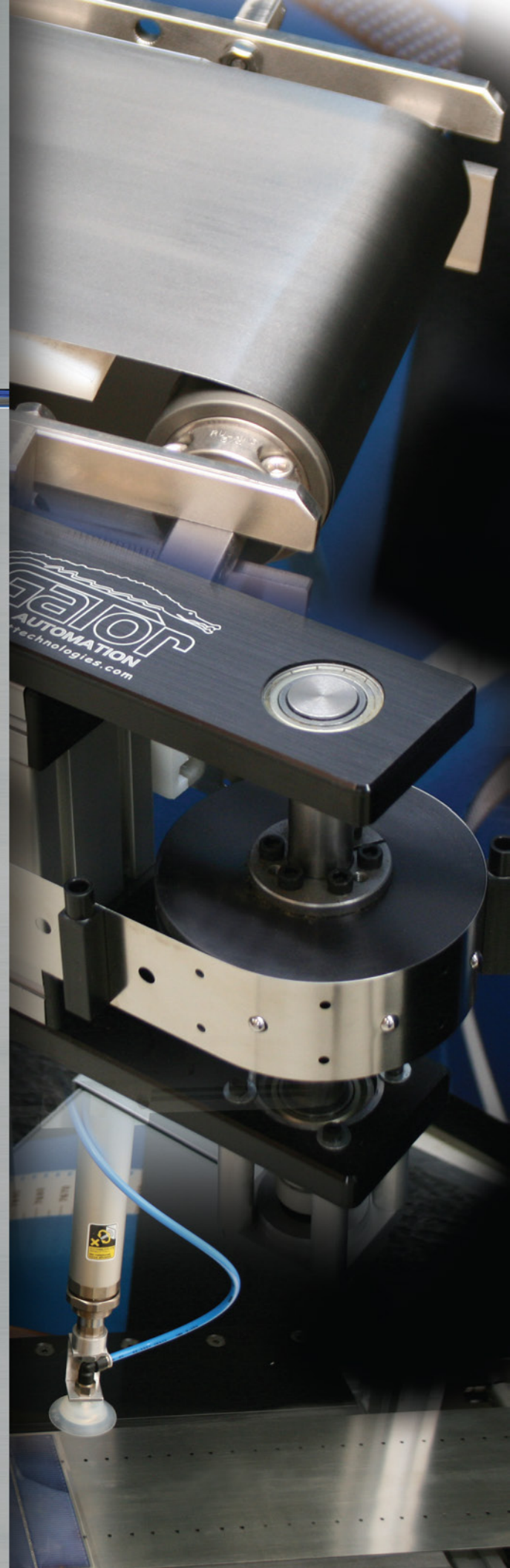

Precision on the *Move*

Design Guide and  
Engineer's Reference  
for Metal Belts





Belt Technologies helps our client companies achieve optimal performance from machinery for precision positioning, timing, conveying, power transmission, packaging, and automated manufacturing operations. For more than 25 years, we have provided a comprehensive resource for application-specific design and manufacture of metal belts, metal tapes, and pulleys.

Metal belts possess many unique properties that result in superior precision, control, longevity, and cost effectiveness. In many cases they are preferable to other belt types (such as rubber and fiberglass) and other power transmission or motion control components (such as linear actuators, lead screws, and chains). Frequently they are the only design option.

To put the advantages of metal belt systems to work, Belt Technologies offers extensive in-house capabilities:

- Engineering and Design Assistance
- Metallurgical Consulting
- High Energy Beam Fabrication
- Complete Tooling Design and Manufacture

Our climate controlled facilities are equipped to produce metal belts, drive tapes, and complementary pulleys in prototype and high volume production quantities.

This document is provided for information and reference. It is a design guide, not a design textbook. Belt Technologies cannot accept responsibility for actual designs attempted using this manual as a basis. Readers should feel free to contact our engineering staff for further information and advice on unusually perplexing applications.



**BELT**  
TECHNOLOGIES, INC

Precision on the *Move*



Belt Technologies has produced this Design Guide to give engineers a reference publication detailing fundamentals of metal belt design and application, with topics including:

- Why Consider Metal Belts for Your Application
- Metal Belts, Drive Tapes, and Applications
  - Pulleys
  - Surface Treatments
  - Design Considerations
- Belt Life
- Metal Belt Materials (Appendix)

We hope this information helps you understand the many benefits of metal belts and gives you the knowledge you need to specify metal belts with confidence.

Because no two customers have identical needs, Belt Technologies designs each product to unique specifications. Therefore, it is important to keep in mind that this Design Guide cannot include every possible application. There may be excellent applications for metal belts, perhaps yours, that are not described.

We invite you to contact Belt Technologies to discuss your ideas with a member of our engineering staff. Please use the design checklist on the inside back cover to help us better understand your project. Our company's long-term success is in large measure due to our ability to continually advance the science of metal belts and develop new solutions.

CONTENTS

3 WHY CONSIDER METAL BELTS FOR YOUR APPLICATION

4 METAL BELTS, DRIVE TAPES, & APPLICATIONS

5 - 6 PULLEYS  
 Designs  
 Materials  
 Tolerances  
 Types of Pulleys

7 SURFACE TREATMENTS  
 Teflon  
 Neoprene or Urethane  
 Silicone  
 Hard Coat Anodize  
 Options

8 - 14 DESIGN CONSIDERATIONS  
 System Design Guidelines  
 Loading  
 Accuracy  
 Positioning Accuracy  
 Repeatability  
 Belt Tracking  
 Timing  
 Tensioning  
 System Frame Stiffness  
 Reverse Bends  
 Cantilevered Shafts  
 Magnetic Permeability  
 Belt Sag  
 Elevated Temperatures  
 Belt Creep  
 Design Imposed Restrictions  
 Belt Life

15 APPENDIX:  
 METAL BELT MATERIALS

16 - 24 PULLEY DESIGN GUIDE  
 A review of general design concepts for pulleys used with metal belts

METAL BELT DESIGN CHECKLIST  
 Inside Rear Cover

Engineers who specify metal belts have options available to them that they do not have when using other products or materials. Some important features and benefits are discussed below.

- **HIGH STRENGTH-TO-WEIGHT RATIO:**  
 This is an advantage in practically every application where high strength, light weight, or both are important.
- **DURABILITY:**  
 Metal belts can withstand sustained exposure to extremes of temperature, hostile environments, and vacuum. A variety of alloys may be used, each with its own resistance to chemicals, humidity, and corrosion. Engineers generally select a belt material based on physical properties, availability, and cost.
- **NO LUBRICATION:**  
 Unlike the links of a chain, a metal belt is a single element and, therefore, does not generate any component friction that requires lubrication. This reduces system maintenance, improves reliability, and keeps the system clean.
- **NONSTRETCHABLE:**  
 Spring steels with a high modulus of elasticity make metal belts virtually nonstretchable as compared to other belt types and chain. This makes them ideal in high performance applications for precision positioning.
- **SMOOTH OPERATION:**  
 Metal belts are free from the pulsation of chordal action often seen in other belt types and chain. This results in precise translation of the control system motion profile.

- **ACCURATE AND REPEATABLE:**  
 Metal timing belts can be fabricated with a pitch accuracy of  $\pm 0.0005$  inches station to station. This high degree of precision is extremely valuable in designing indexing, positioning, or processing equipment.
- **GOOD THERMAL AND ELECTRICAL CONDUCTIVITY:**  
 Metal belts can transmit energy in the form of heat, cold, and electricity.
- **NO STATIC BUILD UP:**  
 Metal belts discharge static electricity, a crucial capability in the manufacture of electronic components such as integrated circuits and surface mount devices.
- **CLEAN:**  
 Unlike HTD or flat neoprene belts, metal belts do not generate particulate and are ideal for food and pharmaceutical processing.
- **CLEAN ROOM COMPATIBLE:**  
 Metal belts do not require lubricants and will not generate dust that would introduce foreign substances into clean room environments. Additionally, they may be sterilized in an autoclave.
- **PRECISE CONSTRUCTION:**  
 Edges are smooth and dimensions are tightly tolerated.





**PLAIN BELTS:**

Plain metal belts are created by welding together two ends of a metal tape to form an endless belt. High energy beam welding techniques, pioneered in the space program, form a high integrity butt weld that is extremely strong and smooth. Some typical plain metal belt applications include:

- Conveying
- Heat Sealing
- Casting
- Imaging

**PERFORATED BELTS:**

Perforated belts are plain metal belts manufactured with precision perforations which can be produced mechanically or by using non-impact methods. They are used in applications such as:

- Timing
- Carriage Positioning
- Vacuum Conveying
- Web Conveying
- Indexing

Figure 1. Plain Belts

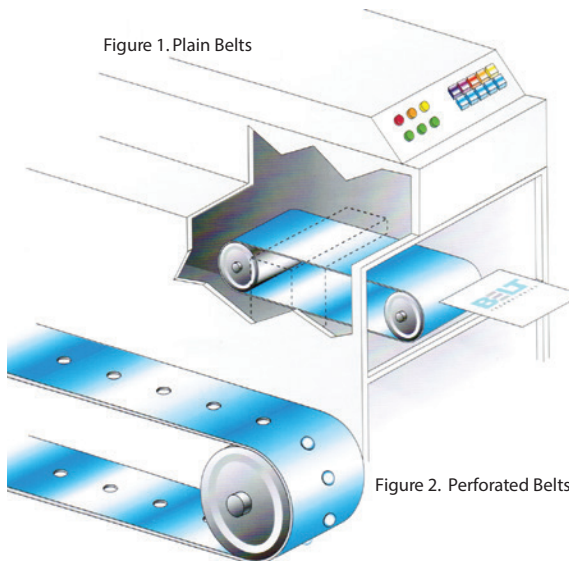

Figure 2. Perforated Belts

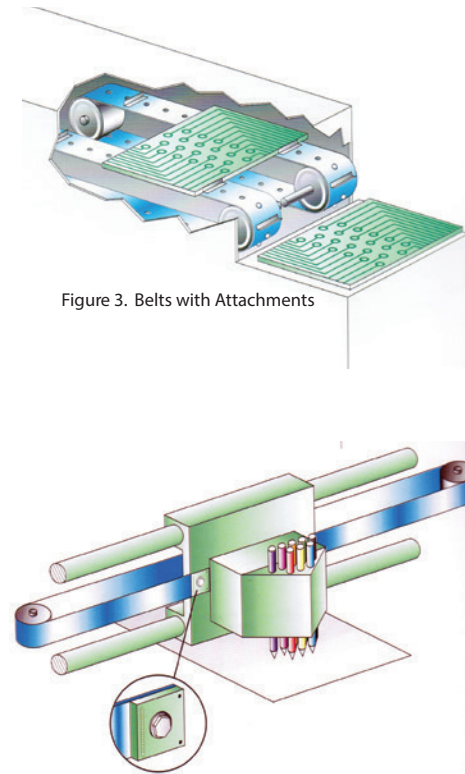

Figure 4. Drive Tapes

**BELTS WITH ATTACHMENTS:**

Perforated metal belts can also be fitted with precision machined, cast, or molded attachments to provide unsurpassed positional accuracy and repeatability, to act as a product transport device, or to control specific stages of a manufacturing process. Applications include:

- Precision Position Indexing for Automated Assembly
- Lead Frame Drives
- Timed Transfer Lines
- Packaging Systems

**DRIVE TAPES:**

Metal drive tapes are made of the same high quality strip as metal belts but, unlike belts, drive tapes are not endless. Drive tapes are fitted with specialized end attachments or perforations. They can perform with zero or near zero backlash in applications including:

- Carriage Positioning
- Plotters
- Robot Arms
- Read/Write Head Positioning
- Optical Element Drives

**COMBINATION BELTS/TAPES:**

Often, combinations of belt options are required in order to satisfy system objectives. Attachments or pockets may be utilized to locate components while a vacuum drawn through the belt's perforation is employed to secure the component in place during transport. Specific edge geometries may be developed to conform to component profiles while attachments locate the components and satisfy timing requirements. Applications include:

- Timed Parts Nesting
- Component Orientation and Conveying
- Automated Dimensional/Electrical Inspection
- High Speed Packaging
- Cutting

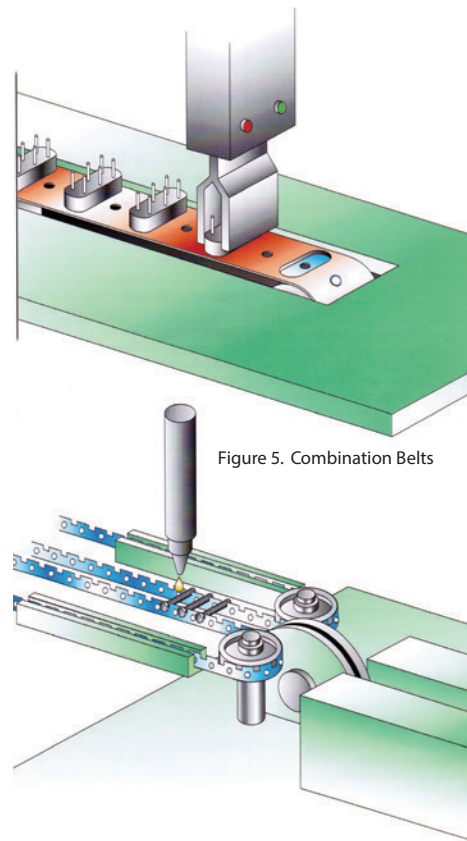

Figure 5. Combination Belts

All metal belts and drive tapes travel around pulleys. Belt Technologies custom designs and manufactures pulleys that optimize the unique characteristics of metal belts.

**DESIGNS:**

Most pulleys for belt systems take one of three forms: round stock, I-beam, or capped tube. Any of these pulley types may be designed with drive lug timing pockets, relief channels, conventional timing teeth or Belt Technologies' patented ball bearing timing teeth.

**Round Stock**

Because of their relatively low cost, round stock pulleys are incorporated into most system designs. Normally, round stock pulleys are used in sizes up to 6" (152mm) outer diameter with widths up to 4" (102mm).

**I-Beam**

As diameter and width increase, rotational inertia considerations may require a pulley with an I-beam cross section. An I-beam profile is machined into a round stock pulley in a fashion that maintains the structural integrity of the pulley while removing substantial amounts of weight, therefore reducing the effects of rotational inertia. Machining holes into the beam section further reduces weight.

**Capped Tube**

These pulleys employ end caps attached to the ends of tube stock having sufficient wall thickness to assure adequate strength. The capped assembly is then machined to meet rigid specifications for roundness and concentricity. Again, it is crucial to reduce weight without compromising strength.

**ISP - Independent Steerable Pulley**

These pulleys are designed to automate the tracking of the belt by changing the relationships across the width of the belt by adjusting the angle of the pulley relative to the belt. Rather than moving the pulley shaft left/right or up/down by pillow block adjustments, the ISP designs fit a variable steering collar and sealed bearing assembly to the body of the pulley. This system can be integrated into either the I-Beam, Round Stock or Capped Tube pulley designs.

**MATERIALS:**

To address the needs of your specific applications, pulleys can be manufactured from a wide range of materials.

**Aluminum**

Aluminum with hard coat anodization is a frequent choice. The combination is strong, light weight, tough, and cost effective. Extremes of temperature can be a limiting factor, however, and out gassing may be an issue in vacuum environments.

**Stainless Steel**

In corrosive operating environments, stainless steel is a good choice. Stainless steel also offers excellent wear and strength characteristics.

There are many different alloys available, each with special advantages.

**Non-Metals**

Certain plastics can offer excellent wear and strength characteristics. In some applications and in high volume, plastic can be less costly than metal pulleys.

**TOLERANCES:**

Table 1 shows typical tolerances for the primary design dimensions of timing and friction drive pulleys. These tolerances are applicable to the three pulley body designs: round stock, I-beam, and capped tube.

Table 1. Pulley Tolerance Up to 14" Diameter

	TIMING PULLEY Inches (mm)	FRICTION PULLEY Inches (mm)
Tape Support Diameter (O. D.)	±.0015" (.038)	± .002 (.051)
Face Width	±.010" (.254)	±.010" (.254)
Bore Diameter	+.001"/-0.0000" (+.025/-0.00)	+.002"/-0.0000" (+.051/-0.00)
Concentricity	.002" (.051)	.002" (.051)
Timing Location	±10 arc seconds	N/A

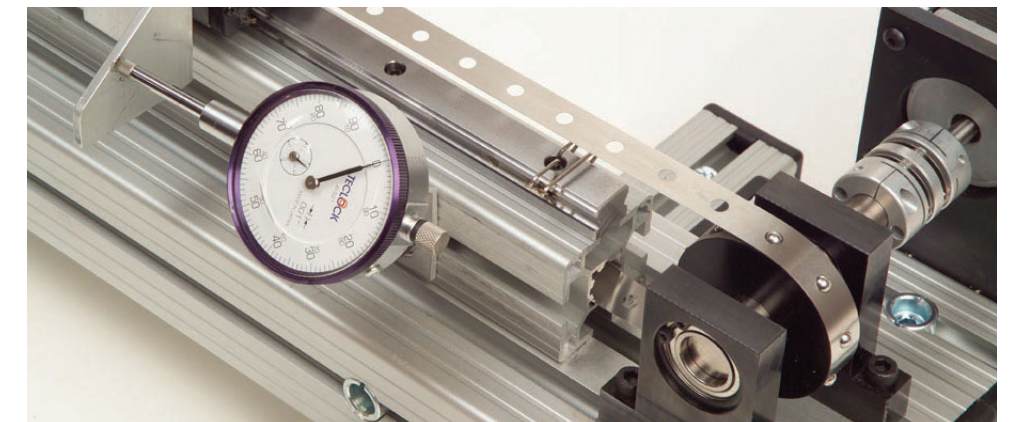



**TYPES OF PULLEYS:**

Even with all the variations in form, material, and design features, pulleys generally serve one of two purposes: friction driving or timing.

Figure 6. Pocketed and Ball Bearing Pulleys



**Friction Drive**

Friction drive pulleys are generally flat faced with no timing element.

Crowning pulley faces is not generally recommended. To discuss the reasons why, please contact a Belt Technologies engineer who is familiar with metal belt dynamics. When crowning is appropriate, two geometries may be used: full radius and trapezoidal. A full radius crown is less stressful on the belt, but is more difficult to machine and, therefore, more costly. The trapezoidal crown is more cost effective and works well, but it should be avoided in applications having high belt tensile loads due to stress risers at the crown's transition points between angled flats. Blending these points can be helpful but does not eliminate the high stress risers.

**Timing**

Timing pulleys have either teeth or pockets, located radially around the outside diameter of the pulley body. Teeth engage timing holes in the metal belt; pockets engage drive lugs on the belt's inner circumference. It should be noted that even in these pulleys, the driving is accomplished by frictional forces generated between the flat belt and pulley surfaces. Teeth or pockets are used only for timing, not for power transmission.

Timing elements, particularly timing teeth, must be hard. Hardness is essential to ensure minimal wear from successive engagements of belt and pulley. As an example, Belt Technologies' patented pulley uses hardened ball bearings as teeth.

When designing a two pulley timing system, the drive pulley should be timed while the idler, or driven pulley, should be a friction drive pulley with relief channels for lugs if necessary.

NOTE: Both friction and timing pulleys can be designed as narrow bodied rolls. Essentially, the narrow bodied roll is a pulley whose width is narrower than the belt that is running on it. They can make belt tracking easier and reduce total pulley weight as well as cost. The pulley face is typically not less than 1/2 the width of the belt.

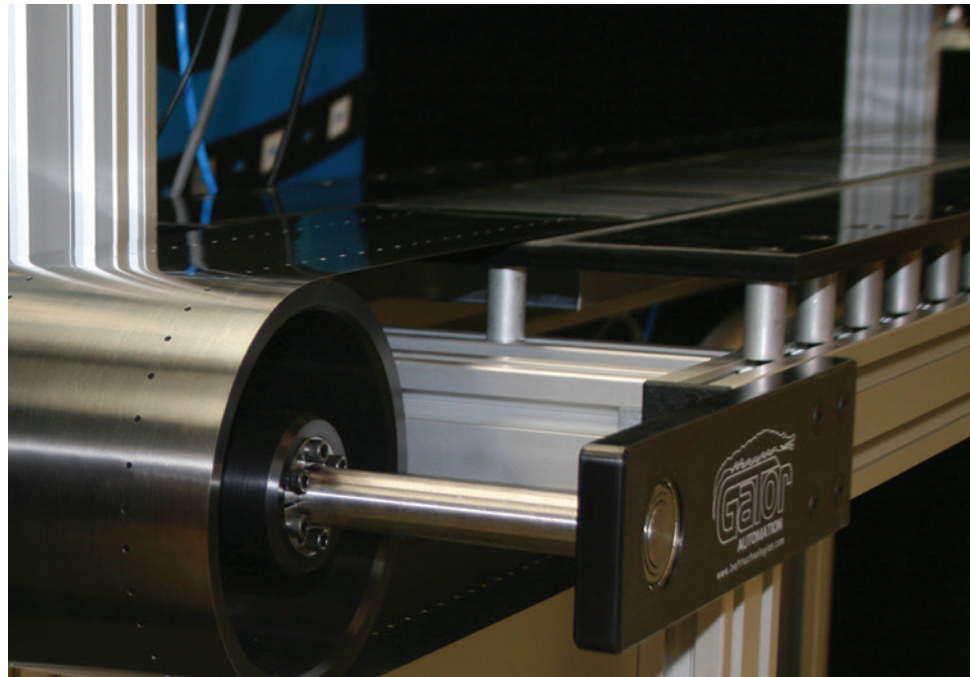
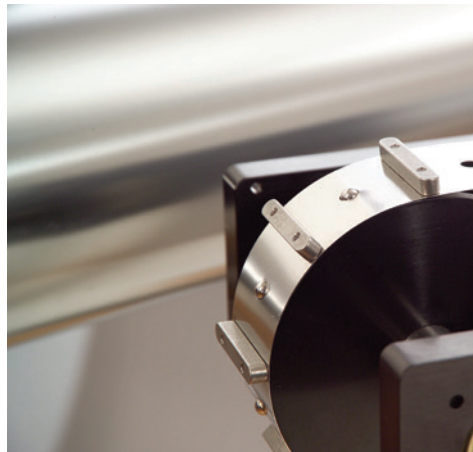
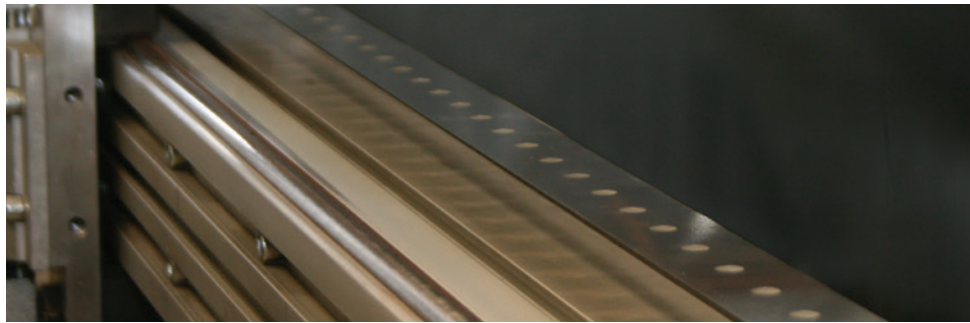

Surface treatments give engineers the opportunity to alter the natural surface properties of a metal belt, tape, or pulley. Surface treatments may be applied to one or both surfaces of a belt or tape, or to a pulley. Application methods include coating, plating, laminating, and bonding.

Depending on the method selected, the thickness of a surface treatment may be as little as .0005". The surface can be uniform or, to provide pockets on the belt surface for transporting small components, punched or die cut. Vacuum holes can be combined with pockets for more positive orientation and retention of delicate parts during transport.

For primary mechanical and physical characteristics of popular surface treatments, see Table 2.

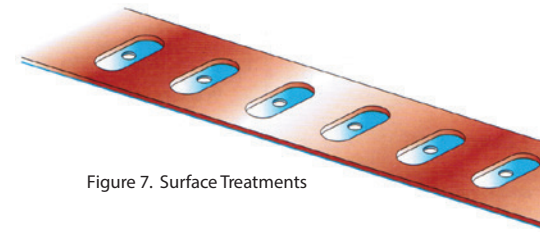

Figure 7. Surface Treatments

**TEFLON®:**

Teflon became a household word as a non-stick coating for cookware. Teflon is actually available in a variety of formulations, each having distinct operating properties regarding release characteristic, lubricity, resistance to abrasion, temperature range, and color.

**GATORCOAT®:**

FDA compliant BTRMC coatings are high release and extremely wear resistant. It's unique three-coat system of internally reinforced metallic material have a high cure, non-stick surface that offers abrasion resistance over 10 times that of Teflon. It is household chemical resistant and features high non-stick properties, stain resistance and performance at high temperatures. It is different from all other non-stick coatings in that the basecoat contains a carefully chosen and blended combination of resins.

The midcoat, (actually a basecoat used in other reinforced systems), also contains the special reinforcing element, while the topcoat is rich in fluoropolymers, and is dedicated entirely to release properties (non-stick characteristic).

**URETHANE OR NEOPRENE:**

Both urethane and open or closed cell neoprene change the surface coefficient of friction of a metal belt and also can act as a nest for delicate parts. These materials are securely bonded to a metal belt. Prior to bonding, they can be die cut when a specific pocket geometry is important.

**SILICONE:**

When the environment is not suitable for other coatings, silicone may be a good option. Silicone has unique properties including a high friction surface, release properties, the ability to withstand elevated temperatures, and extreme flexibility. Bonding silicone to metal belts can be difficult, but workable solutions do exist.

**HARD COAT ANODIZE:**

Hard coat anodization is an electrochemical process used to increase the hardness and wear characteristics and corrosion resistance properties of aluminum pulleys. The process forms a layer of aluminum oxide which becomes an integral part of the metal, both penetrating and building up on all pulley surfaces. The coating thickness is uniform and mirrors the precision of the pulley itself.

**OPTIONS:**

The range of options for surface treatments is so large that it cannot be fully documented in this guide. Unusual surface treatments have included fluorocarbon compounds, copper cladding, gold plating, and powdered diamond bonding. Appropriate specifications will be a function of application and technology.

The Belt Technologies engineering staff will be pleased to discuss issues related to your specific needs.

Table 2. Surface Treatment Characteristics

COATING MATERIAL	CHIEF CHARACTERISTICS	OPERATING TEMPERATURE	THICKNESS Inches (mm)	COLOR
TEFLON® TFE	Anti-Stick	up to 500° F up to 315° C	.001" (.025)	Black Green
TEFLON® FEP	Corrosion Resistance Low Temperature	up to 428° F up to 220° C down to -328° F down to -200° C	.001" to .030" (.025 to .75)	Metallic Gray
GATORCOAT®	Food Contact Approved	up to 600° F up to 315° C	.001" to .006" (.025 to 0.15)	Metallic Gray
SILICONE RUBBER	Excellent Release High Friction	up to 392° F up to 200° C	.004" to 0.125" (0.10) to 3.175	Various
POLYURETHANE Moldable	High Friction	up to 158° F up to 70° C	.008" to .125" (.203 to 3.175)	Various
NEOPRENE RUBBER	Compressibility Die Cut Pockets	up to 158° F up to 70° C	.016" to .250" (.40 to 6.4)	Black



**NOTE TO THE DESIGNER:**

With information from previous sections, you may have begun thinking about the design for your metal belt. This section builds on the previous sections by incorporating elements which will help you optimize system performance. Since every design is unique, it is not possible to discuss every design consideration. You are invited to review your design ideas, numbers, and methods with a Belt Technologies engineer.

**SYSTEM DESIGN GUIDELINES:**

- Any system with metal belts is generally enhanced by following these guidelines:
- Use as few pulleys as possible.
  - Use large pulley diameters.
  - Use pulley systems which avoid reverse bending.
  - Use large length-to-width ratios.

**LOADING:**

Proper system design includes an examination of the various loads transmitted to the belt in use. In addition to steady state operating conditions, consideration must be given to any unusual or intermittent conditions such as potential jam-uploading, high startup loads, or indexing. In general, the belt should be designed to ensure that high loading, should it occur, will not exceed the belt's ultimate strength.

To determine the stress factor on any given belt, add together the results from the following four columns.

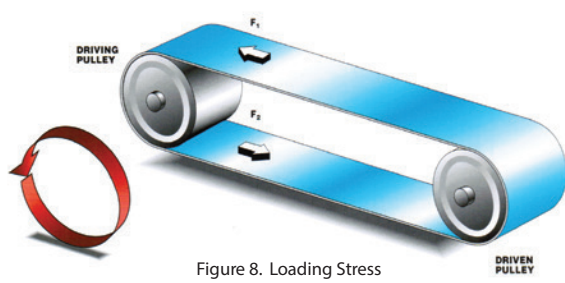

Figure 8. Loading Stress

**1. Determine the working load (Fw) on the belt.**

The working load can be determined from the driving motor torque rating, the load to be moved or accelerated, or by an analysis of the system requirements. For a simple two-pulley system as shown in Figure 8, the working load on the belt (Fw) is  $F_w = F_1 - F_2$ , where:

$D_1$  and  $D_2$  = pulley diameters

$\tau_1$  and  $\tau_2$  = torque action on respective pulleys

$F_1$  and  $F_2$  = force on belt at each pulley in Newtons

$F_w$  is related to the torque by the equation:

$$F_w = \frac{\tau_1}{1/2 D_1} = \frac{\tau_2}{1/2 D_2}$$

And to power by:

$$F_w = \frac{33000 \times \text{HP}}{V}$$

Where: V = velocity in ft/min

And to acceleration by:

$$F_w = ma = (L/g) \times a$$

Where:

L = load on belt in lbs.

$$g = 32.2 \text{ ft/sec}^2$$

a = acceleration of load in  $\text{ft/sec}^2$

**2. Determine the highest load (F1) on the belt.**

Since  $F_w = F_1 - F_2$  as shown in the two pulley example in Step 1, F1 is the greatest force on the belt. To design for the stress condition resulting from this force, we need to calculate its value.

For a friction drive system to operate without slippage, the two forces, F1 and F2 are related by the formula:

$$\frac{F_1 - F_c}{F_2 - F_c} = e^{\mu\theta}$$

Where:

e = 2.71828

$\mu$  = coefficient of friction between belt and pulley

$\theta$  = angle of wrap in radians of belt on pulley

$F_c$  = centrifugal force acting on belt

For a metal belt with a standard finish (such as 0.4 micro-meter) operating on a machined metal pulley, experience has shown the value of  $\mu$  ranges between 0.25 and 0.45.

One advantage of a thin metal belt is that  $F_c$  is usually negligibly small and can be disregarded. Thus, in most cases, the formula can be simplified to:

$$\frac{F_1}{F_2} = e^{\mu\theta}$$

Substituting for F2 and solving for F1, this becomes:

$$F_1 = \frac{F_w e^{\mu\theta}}{e^{\mu\theta} - 1}$$

**3. Determine bending stress (Sb) on belt.**

A significant bending stress is induced in a metal belt as it is repeatedly flexed over a pulley. This stress must be calculated and added to the working stress  $S_w$  (see Step 4) to determine the total stress  $S_t$  on the belt.

The formula for the bending stress is:

$$S_b = \frac{Et}{(1 - u^2)D}$$

Where:

E = modulus of elasticity in psi

t = belt thickness in inches

D = smallest pulley diameter in inches

u = Poisson's Ratio

This calculation requires an assumption of belt thickness and pulley diameter. Pulley diameter may be the easiest to determine because of space limitation or other design requirements. If this is so, pick the maximum possible pulley diameter, then calculate the appropriate belt thickness based on Table 3.

Table 3. Belt Life

PULLEY DIAMETER TO BELT THICKNESS RATIO	BELT LIFE EXPECTANCY
625:1	1,000,000 cycles or greater
400:1	500,000
333:1	165,000
200:1	85,000
Relationships are based on a two pulley friction drive system.	

**4. Determine the total stress (St) on the belt.**

The total stress on the belt is the sum of the working stress ( $S_w$ ) and the bending stress ( $S_b$ ).

$$S_t = S_w + S_b$$

$$S_w = \frac{F_1}{b \times t}$$

Where:

b = belt width

t = belt thickness

Belt Technologies recommends that  $S_t$  not exceed one third the belt material yield strength. For further information, please contact a Belt Technologies engineer.

Belt Technologies recommends a tension of 1000 psi (6.9 N/mm<sup>2</sup>) per belt strand for timing belts and 2000 - 5000 psi (13.8 - 34.5 N/mm<sup>2</sup>) per belt strand for plain belts.

**TYPICAL SIZES AND SPECIFICATIONS**

Metal belts typically range in thickness from 0.002" (0.051mm) to 0.032+'' (0.8mm) resulting in pulley sizes of 2'' (50mm) to 10'' (254mm) in diameter. A typical metal belt with a thickness of 0.005'' (0.127mm) with a 1,000,000 cycle life would require pulleys with a 3.125'' (79.4mm) diameter. Size ranges vary by application and load considerations, so please talk to a Belt Technologies Applications Sales Engineer for help with your design ideas

At this point it is necessary to select various parameters and work back through the calculations to find a combination that will satisfy design requirements. Obviously, using a wider belt reduces working stress without changing bending stress. Larger pulley diameters reduce bending stress, or allow use of a thicker belt which in turn reduces working stress.





**BELT LENGTH ACCURACY:**

One of the most important advantages of a metal belt is its overall accuracy. Perforated belts or belts with attachments can be fabricated with pitch accuracies of ±0.0005". Plain belts and drive tapes can also be fabricated to a high degree of accuracy.

**BELT LENGTH:**

To calculate a length for a metal belt, use the formula below. It is important to know the ideal design envelope of your system before calculating belt length. Larger pulley diameters usually provide optimum belt life, and pulley diameters can be used to estimate belt thickness. See Table 3 for life expectancy. Once a maximum pulley diameter is known, divide it by the pulley diameter to belt thickness ration from Table 3 for optimum belt life in your application. Typical belt thickness range from 0.002" [0.05mm] to 0.032" [0.813mm], and typical pulley diameters range from 2" up.

$$L=(2 \times C)+(D + t) \pi$$

Where:

L = Belt length

C = Center distance between two pulleys

D = Pulley diameter

t = Belt thickness

π = 3.14159

This defines the appropriate length for metal belt systems incorporating two pulley of identical diameter. For systems with multiple pulleys or or pulleys of different diameters, please contact a Belt Technologies Sales Engineer. Contact information is listed on the inside the back cover.

**BELT STRETCH:**

Metal belts are unique, as they will not stretch in normal operation, after achieving a normal preload tension. To calculate preload stretch for a plain belt, use the following equation. For perforated belts, please contact a Belt Technologies sales engineer.

$$\Delta L = PL/AE$$

Where:

ΔL = Stretch in inches

P = Tension load in pounds

L = Initial belt length in inches

A = Belt cross - section area in inches

E = Young's Modulus

(See materials table on page 15)

**ZERO BACKLASH:**

Zero and near-zero backlash positioning systems can be achieved through the use of metal belts. Run in pairs or with inventive design ideas, these drives can be used anywhere tight tolerances exist for back and forth placement accuracy. The illustrations below offer two typical zero-backlash drive suggestions.

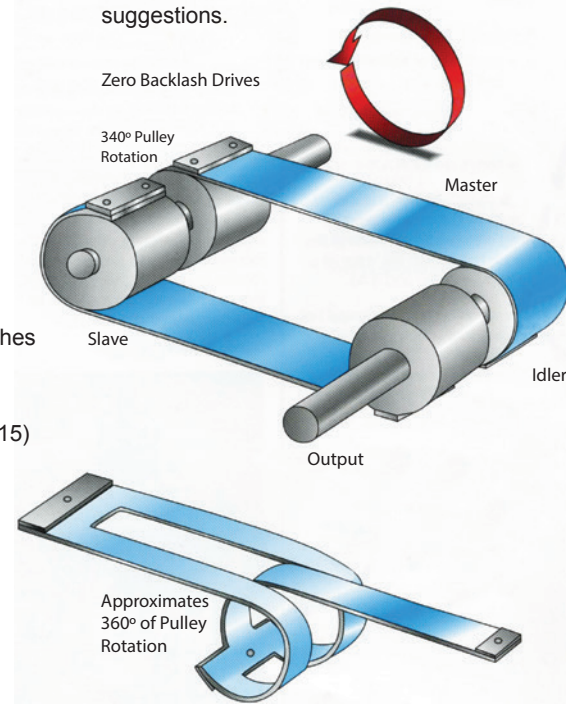

**POSITIONING ACCURACY:**

Positioning accuracy is directly related to the belt pitch tolerance, typically ±0.0005" (0.013mm) for a metal timing belt. Pitch accumulation can be managed with customized tooling, shown as PI in Figure 9, or negatively, shown as Ps in the same graphic. Please consult a Belt Technologies engineer on your requirement.

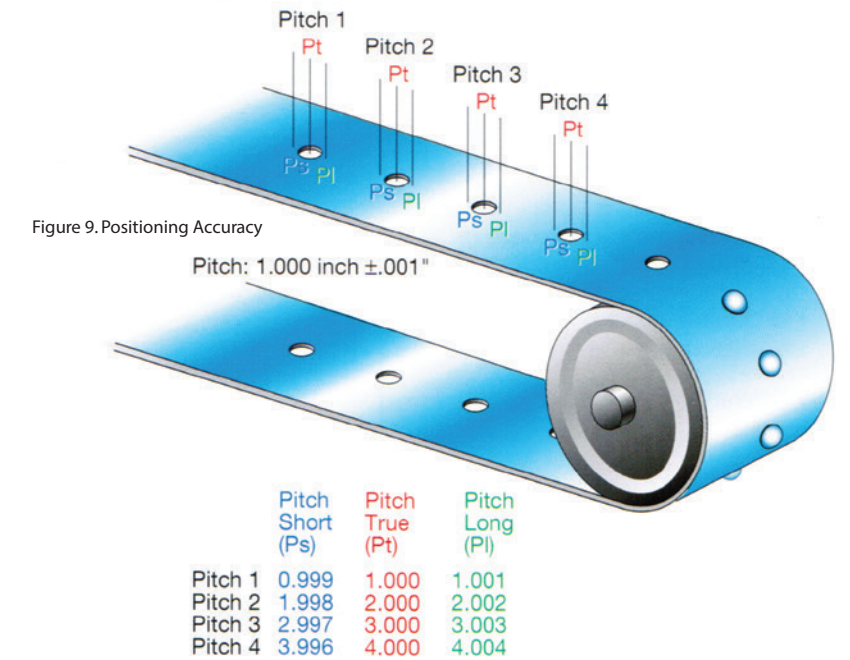

Figure 9. Positioning Accuracy

**REPEATABILITY:**

Repeatability is the ability of a single pitch, on successive rotations of the belt, to return to a home position within a specified tolerance.

Because metal belts do not stretch, repeatability is typically in the range of 0.002" (0.051mm) to 0.005" (0.127mm).

For plain or perforated belts, belts with attachments, or drive tapes, precise motion can be calculated with a high degree of accuracy. Contact a Belt Technologies sales engineer for assistance in determining the specifications for your system.

**BELT TRACKING:**

Given that a metal belt will not significantly stretch under tension, tracking a metal belt can be more difficult than tracking other belt types. A metal belt will not stretch to compensate for:

- Lack of system squareness or alignment
- Uncontrolled pulley shaft deflection
- Differential loading
- Belt camber

Among these, the Design Engineer is probably least familiar with belt camber. Camber, or edge bow, is the deviation of a belt edge from a straight line. Every belt has some camber. Metal belt camber is typically as little as .050" (1.27mm) in 8' (2.44mm). When placed in a squared two pulley system and tensioned, one edge of the belt will be tensioned more than the other because it has a shorter edge circumference. This will cause the belt to track away from the tight edge of tension towards the loose edge when the belt is rotated.

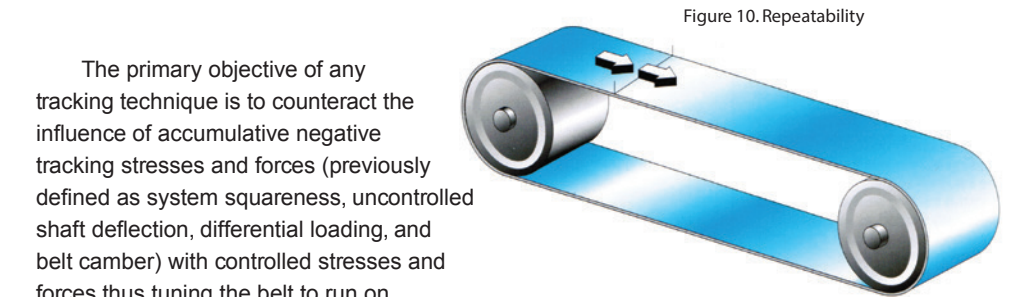

Figure 10. Repeatability

The primary objective of any tracking technique is to counteract the influence of accumulative negative tracking stresses and forces (previously defined as system squareness, uncontrolled shaft deflection, differential loading, and belt camber) with controlled stresses and forces, thus tuning the belt to run on the system.

**ADJUSTABLE PULLEY:**

Belt Technologies has patented an Independently Steerable Pulley (ISP) to aid in tracking of all flat belts, including metal belts. In automated systems, the ISP can be fitted with sensors and a servo motor package to deliver hands-free automated tracking of metal belts. Contact your Belt Technologies sales engineer for a supplemental engineering paper on the Independently Steerable Pulley and how it might benefit your application.

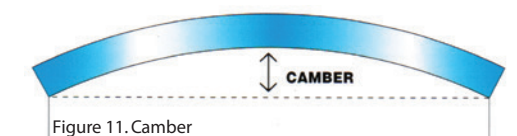

Figure 11. Camber

Three basic techniques are used to track belts on systems using friction pulleys, timing pulleys, or both:

- Pulley axis adjustment
- Crowning friction drive pulley
- Forced tracking

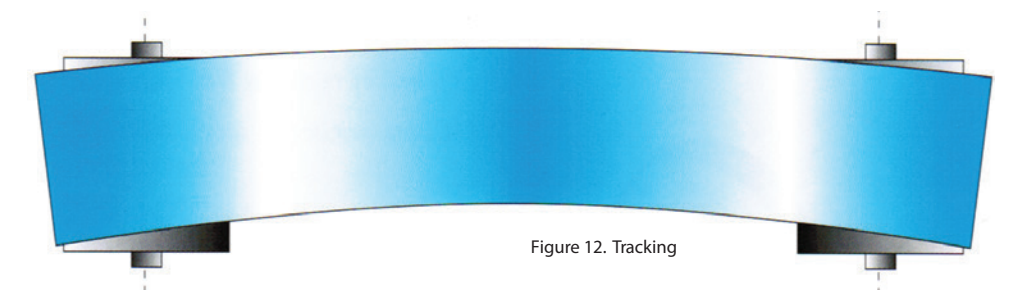

Figure 12. Tracking



**Pulley Axis Adjustment:**

Adjusting the pulley axis in a metal belt system as shown in Figure 13 is the most effective way of tracking a metal belt. Belt edge tensions are changed in a controlled manner, thus steering the belt. The technique is equally applicable to both flat faced and crowned pulleys.

Ideally, both the drive and idler pulleys would have adjustable axes. In reality, however, only the idler is adjusted. The drive pulley is usually difficult to adjust due to its interface with motors or other power transmission devices.

**Crowning Friction Drive Pulleys**

When crowned friction drive pulleys must be used, it is in conjunction with—not in place of—axis adjustment. This is because crowned pulleys will not self-center a metal belt. Crowned pulleys work best on thin belts as the belt web must conform to the crowned face of the pulley. While increased tension can be used to achieve belt to pulley face conformity, tension cannot be so high as to cause permanent belt deformation. The best face geometry for a crowned pulley is a full radius, with the crowning being no more than the belt thickness.

Figure 14. Forced Tracking

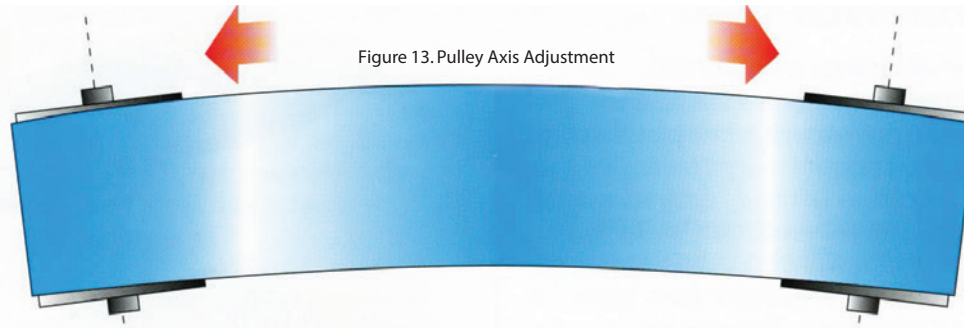
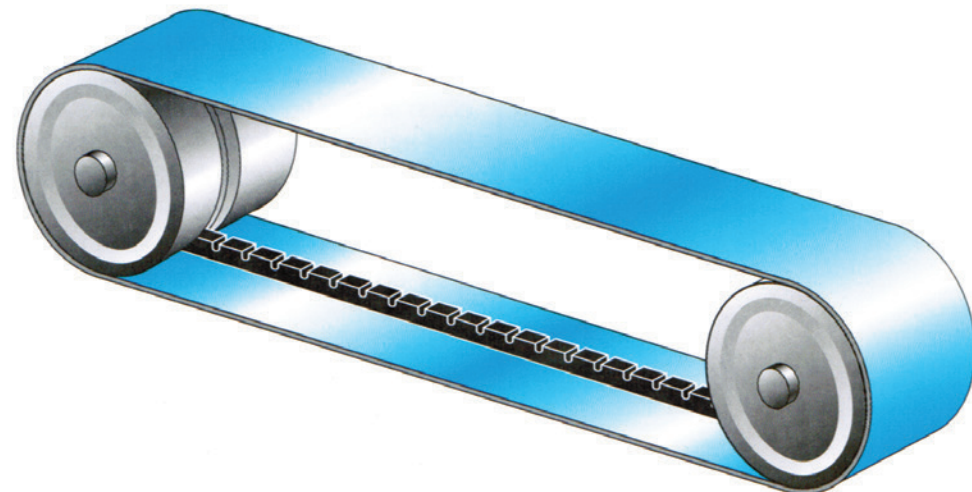

Figure 13. Pulley Axis Adjustment

**Forced Tracking**

In cases where simple axis adjustment cannot completely eliminate improper tracking, forced tracking methods such as cam followers or glass-filled Teflon® flanges may be necessary and acceptable. System design relationships may need to change, such as using a thicker belt than might be otherwise recommended, since forced tracking techniques can contribute to a decrease in expected belt life.

An alternative forced tracking technique for wider belts employs a V belt bonded to the inner circumference of the metal belt. This two element belt, which Belt Technologies calls Metrak<sup>®</sup>, distributes tracking stresses on the V belt rather than on the metal belt, thus maximizing belt life in a forced tracking system (Figure 14).

Timing teeth, discussed in the next section, are for timing only and should not be used as a tracking mechanism.

**Timing:**

Timing pulleys for metal belts are either toothed or pocketed, each engaging respective belt perforations or drive lugs.

Care should always be taken in the design of timing pulleys to ensure that all timing elements have spherical or involute radii. This ensures smooth engagement and disengagement of the belt and pulley. To avoid problems due to accumulated tolerances, the diameter difference between driving and driven components typically should be at least ±0.005" (0.127mm) to ±0.007" (0.178mm). Zero or near zero backlash applications are a special case.

When manufacturing a toothed pulley, each timing tooth is inserted into a hole machined in the pulley body. Great care must be given to the radial location of each tooth to ensure overall pitch accuracy.

While designing a timing pulley, it is critical that the pitch diameter be at the neutral axis of the belt (one half the belt thickness for a thin flat belt), not at the base. Since metal belts are generally thin, there is a temptation to neglect their thickness in calculating the pulley tape support diameter. Failure to include the belt thickness in these calculations results in mismatching of timing elements.

The tape support diameter can be determined by the formula:

$$D = \frac{NP}{\pi} - t$$

Where:

N = number of pitch lengths or teeth on a pulley

P = perforation pitch

t = belt thickness

**TENSIONING:**

Friction drive systems can operate with tensions as loose as a bicycle chain and as tight as a guitar string. Belt tension is extremely important in timing systems and should be kept as low as possible. In general, low belt tension improves belt life and reduces wear on other system components.

Belt tension should not be increased to reduce sag between pulleys (see BELT SAG, this page). Over tensioned belts may develop a crossbow, much like that on a tape measure. In addition to cross bow, over tensioning will cause uneven motion, reduce repeatability, and reduce belt life.

Belt tension should be determined by operating the system and selecting the lowest possible workable tension. This can be maintained through the use of air cylinders, springs, or jack screws.

Belt Technologies recommends 2000 to 5000 psi (6.9 to 34.5 N/mm<sup>2</sup>) for friction systems and 1000 psi (6.9 N/mm<sup>2</sup>) for timing systems.

Figure 15. Timing Pulleys

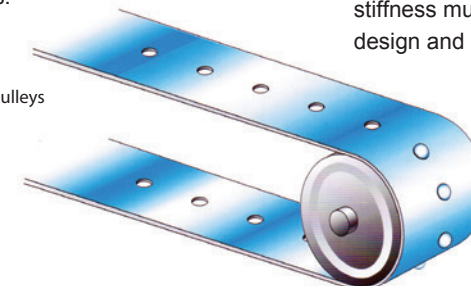

**SYSTEM FRAME STIFFNESS:**

A stiff system frame is necessary to allow fine adjustments for timing and belt tracking. If there is uncontrolled flex in the system frame, the system will bow when the belt is tensioned. Offsetting one force (system flex) with another force (axis adjustment) does not provide a controlled system and can result in tracking problems. To make sure that any axis adjustments are controllable, it is important to design sufficient stiffness into the system.

**REVERSE BENDS:**

The best system design utilizes two pulleys. Adding reverse bends to the system adds bending stress, compromising belt life. Because each pulley can have a steering influence, tracking problems can result.

**CANTILEVERED SHAFTS:**

It is preferable for pulley shafts to have solid termination points at each end. Cantilevered shafts can create a pivot. When tension is introduced, the shaft may deflect and can cause tracking problems. If cantilevered shafts are necessary, their stiffness must be ensured through the frame design and shaft rigidity.

**MAGNETIC PERMEABILITY:**

Magnetic permeability is commonly defined as a measure of the ability of a substance to carry magnetism as compared to air, which has a permeability of 1.

Three hundred series stainless steels are considered to be nonmagnetic, but the cold working used to produce their spring temper and high tensile strength results in an increase in magnetic permeability. Therefore, a 301 full hard has a greater magnetic permeability than 301 half hard. Generally, 316 stainless has the lowest magnetic permeability.

Refer to the Appendix for rated magnetic permeability properties of common metal belt alloys.

**BELT SAG:**

When the span between pulleys is long, the belt can sag. Even on the tight side of tension there is some sag. To ensure proper tension and prevent sagging, drag the working surface of the belt across a stationary support surface such as ultra-high molecular weight materials (UHMW).



**ELEVATED TEMPERATURES:**

If a metal belt will be exposed to elevated temperatures, it is crucial that the material selected for the belt, as well as any attachments or surface treatments, be able to withstand the temperature. Consideration also must be given to the expansion and contraction of the materials as temperature fluctuates. Changes due to temperature will impact timing, tracking, tension, flatness, and other factors.

Table 4 lists the principal alloys used in specific temperature ranges as well as corresponding thermal expansion coefficients and yield strengths. Table 5 illustrates how physical properties of 17-7 CH-900 change as a function of temperature.

Table 5. Physical Properties vs. Temperature Changes (17-7 CH-900)

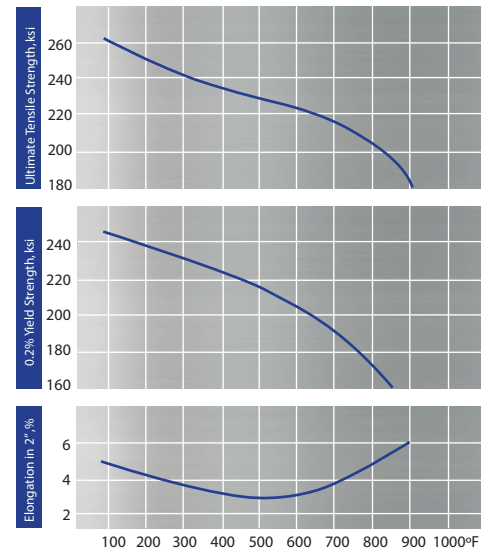

ALLOY	TEMPERATURE RANGE °F (°C)	MEAN COEFFICIENT OF THERMAL EXPANSION 10 <sup>-6</sup> IN/IN/°F (cm/cm/°Cx10 <sup>-6</sup> )	MEAN YIELD STRENGTH OF TEMPERATURE RANGE IN 1000 PSI (N/mm <sup>2</sup> )
301/302 Full Hard	68° to 400° (20° to 205°)	9.8 (17.6)	160 to 135 (1100 to 930)
17-7 CH-900	400° to 800° (205° to 425°)	6.6 (11.9)	220 to 170 (1500 to 1170)
Inconel® 718 Solution Annealed and Heat Treated	800° to 1,000° (425 to 540)	8.4 (15.1)	157 to 155 (1080 to 1070)

Table 4. Elevated Temperature Characteristics of Principal Alloys

**BELT CREEP:**

Belt Creep is a phenomenon associated with power transmission between a drive pulley and the tensile member of the belt. Due to creep in a friction drive system, the pulley actually moves slightly faster than the belt.

Consider Figure 16. The 180° of wrap between drive pulley and belt is divided into two arcs:

- The idle arc (where no power is transmitted)
- The effective arc, also called the angle of creep (where power transmission occurs)

Within the idle arc, the belt and pulley surfaces are in static contact and no power is transmitted. The belt runs onto the pulley with tight-side tension T<sub>1</sub> and speed V<sub>1</sub> which matches the surface speed V<sub>1</sub> of the drive pulley. Both speed and tension remain constant as contact continues through the idle arc.

Figure 16. Creep Theory  
AB is the idle arc. BC is the effective arc.

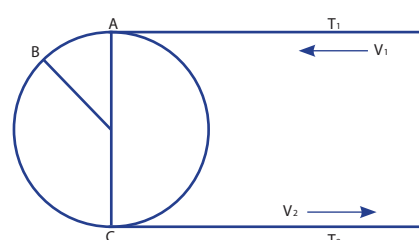

Within the effective arc, the belt and pulley surfaces are in sliding contact and the surface speed of the pulley is greater than that of the belt. This phenomenon is caused by dimensional changes in the belt due to the differential forces acting on it as it passes around the pulley. As sliding contact occurs, frictional forces are developed to match changes in belt tension and power is transmitted.

Because the tensile member of a metal belt is the metal belt with its associated high modulus of elasticity, creep in a metal belt is much less than that for belts made of most other materials.

If not controlled, however, creep in a friction drive metal belt results in a loss of repeatability. Fortunately, creep in metal belts is easily controlled.

Timing teeth or lugs are the most common way to combat creep. The number of timing locations should be the smallest number possible which prevent creep from occurring. In many systems it is possible to have as few as six to eight timing locations in the circumference of the pulley.

**APPENDIX: METAL BELT MATERIALS**

Particularly demanding applications, such as those involving high temperatures, extremely corrosive environments, or unusual electrical or magnetic requirements may preclude the use of certain alloys for metal belts and drive tapes. The following Materials Table summarizes important selection criteria.

**DESIGN IMPOSED RESTRICTIONS:**

Application restrictions such as space limitations, or unusual chemical, thermal, electrical, or system requirements, may demand design trade-offs. Consider these examples:

- Metal belts do operate on pulleys with diameters as small as .25"/6.35mm, but belt life is reduced.
- Belts operate in ovens up to 1,094°F/590°C, but because much of the belt's strength comes from cold working or specific heat treatments, such high temperatures reduce belt strength. Refer to Table 6.
- Doctor blades can induce a cupping effect across the belt width. Properly designed doctor blades such as those made of UHMW can minimize the negative effects.

**BELT LIFE:**

Belt life means different things to different people and different processes. Belt life of 10,000 revolutions may be excellent for one application; another belt may make 10,000 revolutions each hour.

So how long can you expect your metal belt to last? While not trying to avoid what is a fair question, the best answer is: it depends.

It depends on factors such as system design, material strength, environment, stress, tension, surface treatments, attachments, etc. The same factors that have an affect on the design of your system and your metal belts also effect belt life.

With the preceding in mind, it is indeed reasonable to say that metal belts have the potential to significantly outlive other belt types and chain. They also have the potential to be more accurate and repeatable, lighter and faster, and more cost effective.

A discussion with a member of our engineering staff can help you estimate the belt life you can expect in your specific application.

Table 6. Some of the most popular metal belt alloys and their room temperature engineering properties

ALLOY	YIELD STRENGTH (0.2% OFFSET) 1000 PSI (N/mm <sup>2</sup> )	TENSILE STRENGTH 1000 PSI (N/mm <sup>2</sup> )	ELONGATION IN 51mm %	HARDNESS	TENSILE MODULUS OF ELASTICITY IN 10 <sup>6</sup> PSI (in 10 <sup>5</sup> n/mm <sup>2</sup> )	POISSON'S RATIO	DENSITY #/IN <sup>3</sup> cal/cm <sup>2</sup> /sec/°C/cm	THERMAL CONDUCTIVITY (32° TO 212° F) BTU/FT <sup>2</sup> /HR/°F/IN cm/cm/°C x 10 <sup>-6</sup> (0° to 100° C)	THERMAL EXPANSION COEFFICIENT (32° TO 212° F) in/in/°F cm/cm/°C x 10 <sup>-6</sup> (0° to 100° C)	MAGNETIC PERMEABILITY	CORROSION RESISTANCE
301 FULL HARD	160 (1100)	180 (1240)	5-15	RC40-45	28 (1.93)	.285	0.29 (7.9)	113 (.039)	9.4 (16.9)	L-M	M
301 HIGH YIELD	260 (1790)	280 (1930)	1	N/A	26 (1.79)	.285	0.29 (7.9)	113 (.039)	9.4 (16.9)	M-H	M
302 FULL HARD	160 (1100)	180 (1240)	1-5	RC40-45	26 (1.93)	.285	0.29 (7.9)	113 (.039)	9.6 (17.3)	L-M	M-H
304 FULL HARD	160 (1100)	180 (1240)	1-5	RC40-45	26 (1.93)	.285	0.29 (7.9)	113 (.039)	9.6 (17.3)	L-M	M-H
316 FULL HARD	175 (1200)	190 (1310)	1-2	RC35-45	28 (1.93)	.285	0.28 (7.9)	97 (.036)	8.9 (16.0)	L	H
716 FULL HARD	210 (1450)	260 (1790)	5-10	RC52	32 (2.20)	.285	0.28 (7.9)	170 (.059)	5.9 (10.6)	H	L-M
17-7 CONDITION C	185 (1275)	215 (1480)	5	RC43	28 (1.93)	.305	0.28 (7.8)	114 (.037)	8.5 (15.3)	M-H	M-H
17-7 CH-900	240 (1655)	250 (1720)	2	RC49	29 (2.00)	.305	0.28 (7.8)	114 (.037)	6.1 (10.9)	M-H	M-H
INCONEL® 718 CARBON STEEL	175 (1200)	210 (1450)	17	RC41	29 (2.00)	.284	0.29 (7.9)	86 (.030)	6.6 (11.9)	L	H
CARBON STEEL SAE 1095	240 (1650)	260 (1790)	7-10	RC50-55	30 (2.07)	.287	0.29 (7.9)	360 (.124)	5.8 (10.5)	H	L
TITANIUM 15V-3CR-3Al-3SN	150 (1030)	165 (1140)	11	RC35	15 (1.03)	.300	0.17 (4.7)	56 (.019)	5.5 (9.7)	L	H
INVAR 36	50 (340)	75 (520)	30	RB80	20 (1.38)	.317	0.30 (7.9)	120	2.1 (1.2)	L	M-H



**A REVIEW OF GENERAL DESIGN CONCEPTS FOR PULLEYS USED WITH METAL BELTS**

- The use of crowned and/or flanged pulleys is not universally recommended for metal belt applications. These designs are used selectively and should be utilized only after contacting a Belt Technologies Engineer who is familiar with both metal belt dynamics and application idiosyncrasies.

- The manufacture of either friction drive or timing pulleys for precision systems using metal belts is not a matter of simply turning round stock. The precision and repeatability of the metal belt will only be as good as the precision of its complementary pulleys.

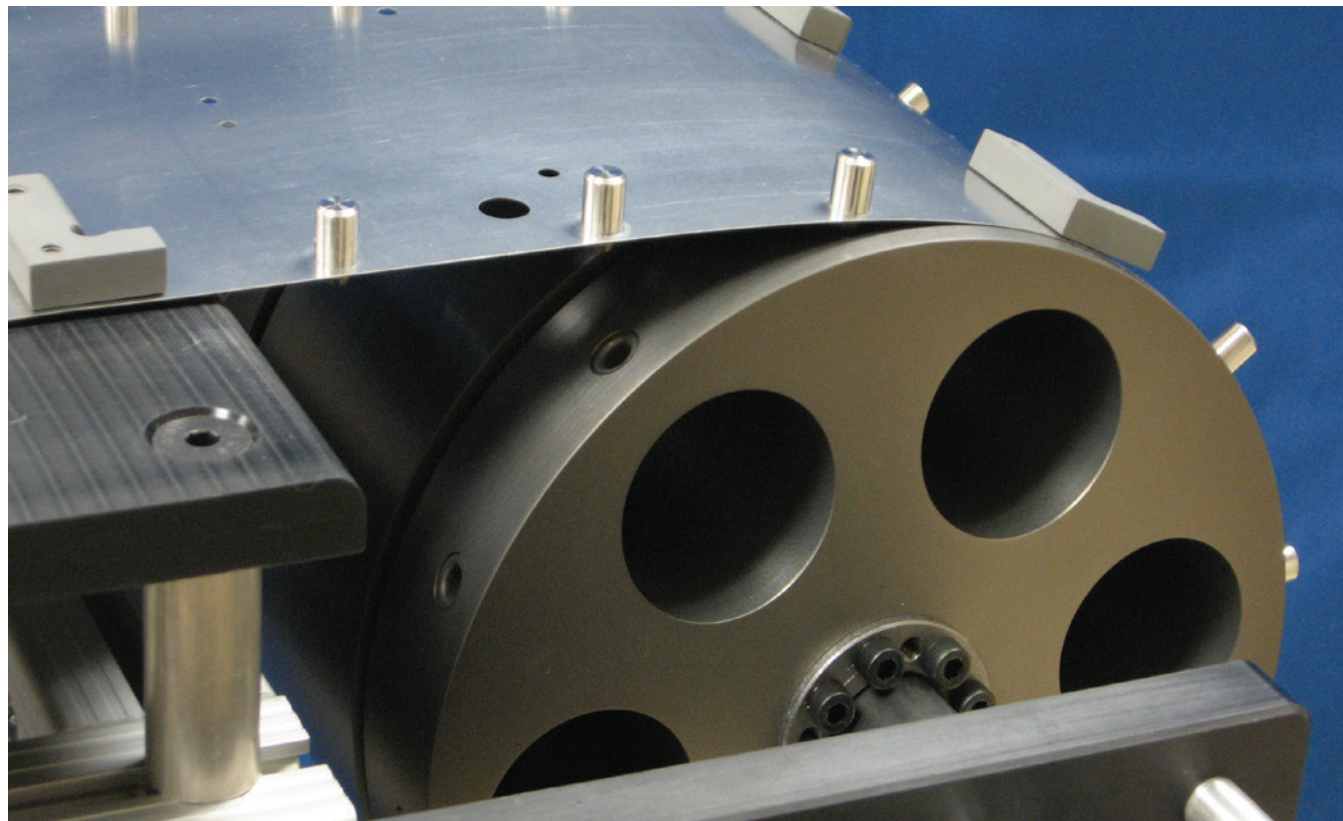
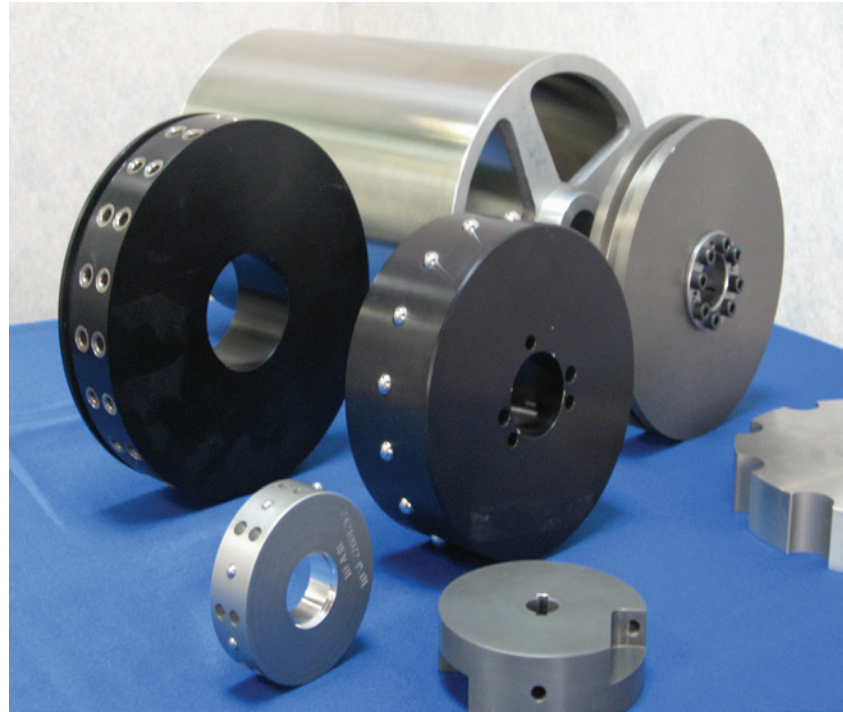

**PULLEY BODY MATERIALS:**

Once the pulley diameter has been determined, the Design Engineer needs to evaluate the best material for the pulley body, considering pulley weight, corrosion resistance, wear resistance, coefficient of friction, and cost. Most pulleys specified and manufactured by Belt Technologies are made of 6061-T6 aluminum with hard coat anodize. Aluminum is light weight, easy to machine, and stable under load. When hard coat anodized, these pulleys have wear resistant surfaces with a proper coefficient of friction to drive the metal belt. For timing pulleys, hardened timing elements can be press fit into the aluminum pulley body. Toothed pulleys are based on a patented Belt Technologies' design (U.S. Patent # 5,129,865) which uses bearing balls (Fig. 1) as timing teeth. An alternate timing design makes use of modified drill bushings (Fig. 2) which are pressed into the TSD surface of the pulley. These bushings act as timing pockets which engage timing lugs on the belt.

Stainless steel is used selectively as a pulley body material in metal belt applications. Type 304 is selected for its corrosion resistance, and while less corrosion resistant, Type 440-C is used in those applications requiring a through hardness in the order of RC50. These choices come at the expense of greatly increased weight and cost. In the case of Type 304, tight tolerances are more difficult to hold as a result of temperature build up and resulting thermal expansion when the pulley is being machined.

Plastics and composites are also used as pulley body materials. They offer the lowest weight, but not necessarily the lowest cost. As with aluminum, hardened timing elements can be press fit into the pulley body. Bores, keyways, and taps can be added via QD® bushings. With the proper choice of materials, wear resistance is excellent, no particulate is generated, and the coefficient of friction complements the metal belt system.

Following are formulas to approximate the weight in pounds of solid round stock pulleys made of the materials described:

Stainless Steel	$(.223 \times D^2) \times \text{Width}$
Aluminum	$(.077 \times D^2) \times \text{Width}$
Plastic	$(.040 \times D^2) \times \text{Width}$

Sizing the belt to the pulley is important. Most metal belt pulleys have a face width of 3/4 of the belt width. The Application Sales Engineer and Design Engineer can make recommendations for the proper pulley size to belt width ration depending on the application, tracking requirement, weight and what type of pulley configuration is chosen.

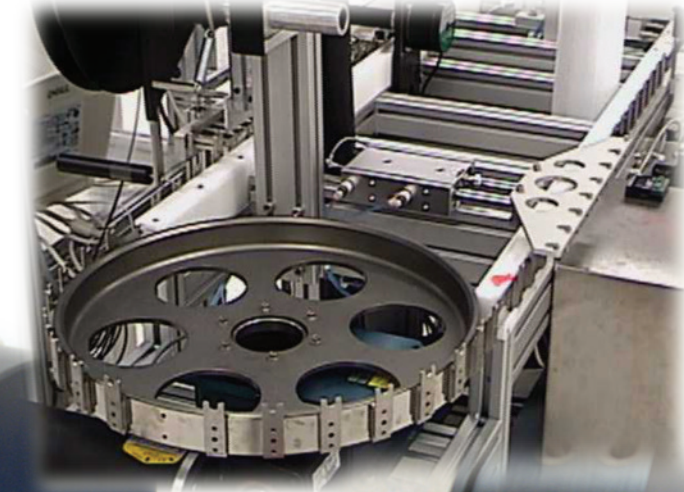

Fig.1 - Bearing Ball Timing Pulley

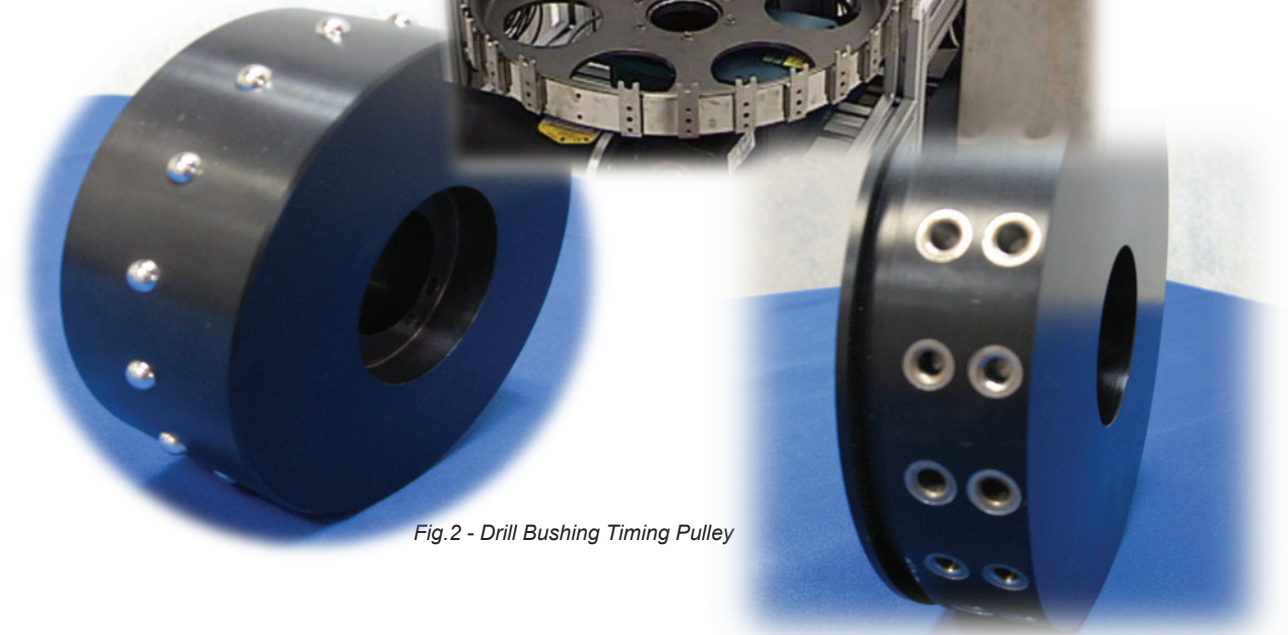

Fig.2 - Drill Bushing Timing Pulley



**DIAMETER:**

When designing a pulley for a metal belt application, a critical design factor is the pulley's diameter. There are two considerations when determining diameter; the diameter which is best for any design constraints of the system, and the diameter which best manages bending stress in the metal belt to assure optimum performance and longevity.

The proper pulley diameter in a given application is defined in terms of a pulley diameter to belt thickness ratio. Ideally, this ratio will be 625:1 or more. This relationship typically results in total stresses which are one-third the yield strength of the metal belt (with total stresses defined as the sum of bending, working, and loading stresses).

As the diameter to thickness ratio decreases, belt bending stress increases, and belt life is reduced. Based on bending stress life testing conducted by Belt Technologies, the following table details expected belt life in a friction drive system for select pulley diameter to belt thickness ratios, without consideration for other stresses which may impact belt life.



Table 1. Expected Belt Life in Friction Drive Systems for Different Pulley Diameter to Belt Thickness Ratios

Diameter/Belt Thickness Ratio	Belt Life
625:1	Minimum of 1 Million Cycles
400:1	500,000 Cycles
333:1	165,000 Cycles
200:1	85,000 Cycles

*(With a cycle defined as one complete belt revolution around a two pulley system)*

A timing pulley used with a metal belt must be designed with an O.D. (or with a metal belt what is known as a Tape Support Diameter, or TSD) such that the metal timing belt will be driven at its neutral axis. This assures smooth engagement and disengagement of the belt to the pulley.

For most systems, the neutral axis has been determined to be one-half the belt thickness. The formula to determine the TSD of the pulley which results in the belt being driven at its neutral axis is:

$$TSD = \frac{N \times P}{\pi} - t \text{ where:}$$

- TSD = Tape Support Diameter
- N = Number of timing elements
- P = Timing pitch
- t = Belt thickness

The timing pulley TSD is approximated by the preferred 625:1 pulley diameter to belt thickness ratio, then adjusted to achieve a balance between the number of timing elements, timing pitch, and belt thickness to obtain the appropriate TSD.

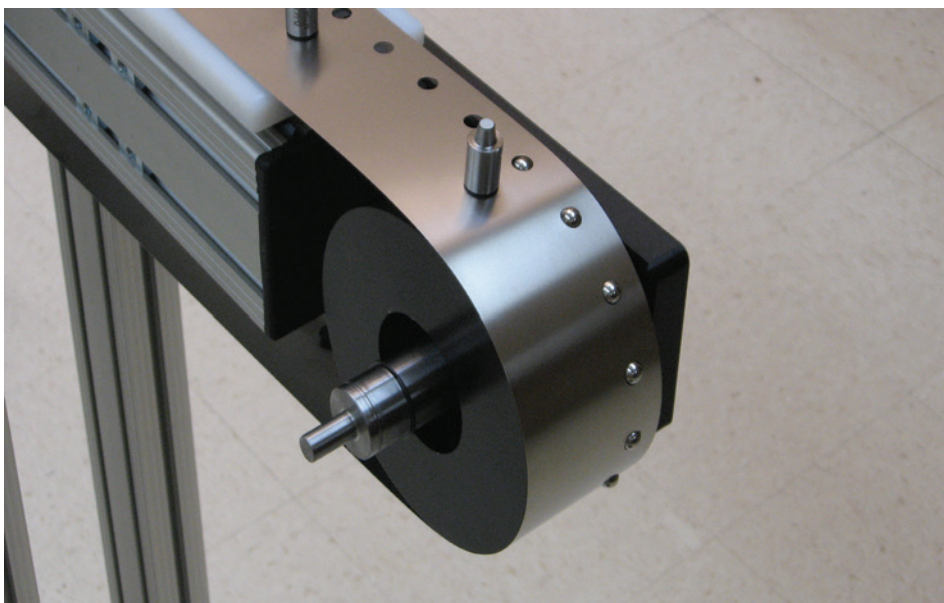

**PULLEY BODY GEOMETRIES:**

High throughput, precision position indexing for automated assembly and inspection systems require low weight and low rotational inertia pulleys. When the system index profile is integrated to the belt/pulley system it may be found that solid round stock pulleys are not the proper design. Alternate pulley body designs are the I-Beam and the Capped Tube. The I-Beam design is used for pulleys up to 8" of face width, after which the Capped Tube becomes the preferred design. Both options are relatively expensive as I-Beam requires a great deal of machining, and Capped Tube requires increased fabrication.

**TRACKING:**

When considering pulley design, the Design Engineer needs to consider how the metal belt is going to be tracked. Traditional elastomeric belt tracking designs such as crowning the face of the pulley or using flanges are only used selectively to assist in tracking metal belts. Crowned pulleys help to stabilize any off-tracking characteristic of a metal belt, but will not self-center the metal belt. Flanges, with the exception of Teflon® flanges as detailed later, are used at the expense of belt life.

A belt's tracking characteristic is a function of uncontrolled stresses and forces acting on the belt. Belt Technologies recommends controlling these stresses and forces to the Design Engineer's advantage. The belt and pulleys are tuned relative to one another using pulley axis adjustment. The belt is steered to a stable tracking state, with the center of the belt width at the center of the pulley width.

Traditionally, axis adjustment has been introduced by adjusting pulley shaft terminating pillow blocks left/right and up/down, with belt tracking accomplished by an iterative process of such adjustments. Using a Belt Technologies Independently Steerable Pulley (U.S. Patent #5,427,581) is substantially easier. This design is based on the use of a steering collar and bearing assembly which press fits into the body of an idler pulley. Rotating the pulley shaft rotates the steering collar, which changes the pulley's face angle relative to the shaft. This controlled use of stresses and forces tracks the belt quickly and dynamically.

Regarding the use of flanges, Belt Technologies does not recommend the use of metal flanges, as the rotary scraping action of the flange against the belt edge results in greatly reduced belt life. We have perfected a design using glass filled Teflon® which works with metal belts as thin as 0.005 inch. Teflon® flanges are attached to the pulley body via a bolt hole circle in both the flanges and the pulley body.

The balance of this Design Guide will detail pulley design standards for the major pulley types and body styles. Included will be: Friction Drive, Type I and Type II Timing, I-Beam, Capped Tube, and Belt Technologies' Patent # 5,427,581 Independently Steerable Pulley.

**ISP / I-BEAM PULLEY**

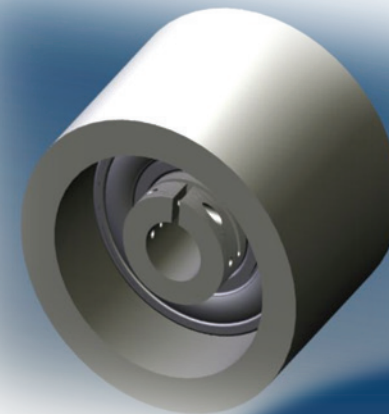

**CAPPED TUBE PULLEY**

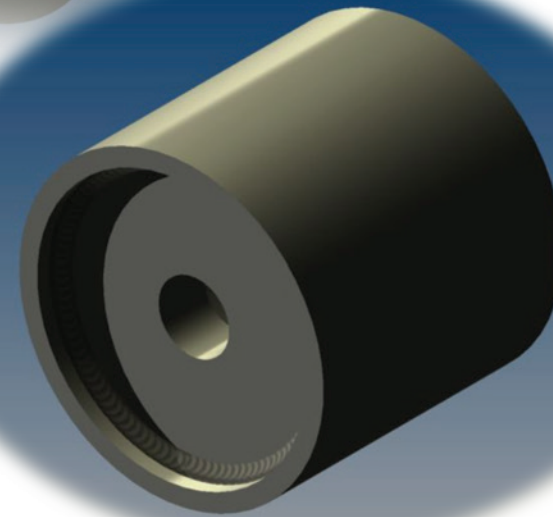

**TEFLON® FLANGED PULLEY**

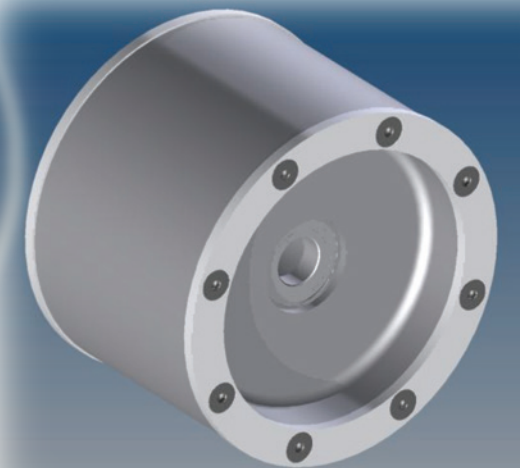



**FRICION PULLEY DESIGN:**

To maximize belt life, whenever possible metal belts should be used with friction pulleys. When an application requires timing or repeatability, a timing pulley is used at the driving end of the system and a friction guide pulley at the driven end of the system.

The drawing and the table below detail typical dimensions and corresponding tolerances of a friction pulley design. To minimize tracking complications, Belt Technologies manufactures these pulleys to a 0.002" concentricity.

Belt Technologies custom manufactures pulleys for each application. The TSD sizes indicated are for illustrative purposes only and are intended to delineate the range of sizes and the interrelationships of other design criteria.

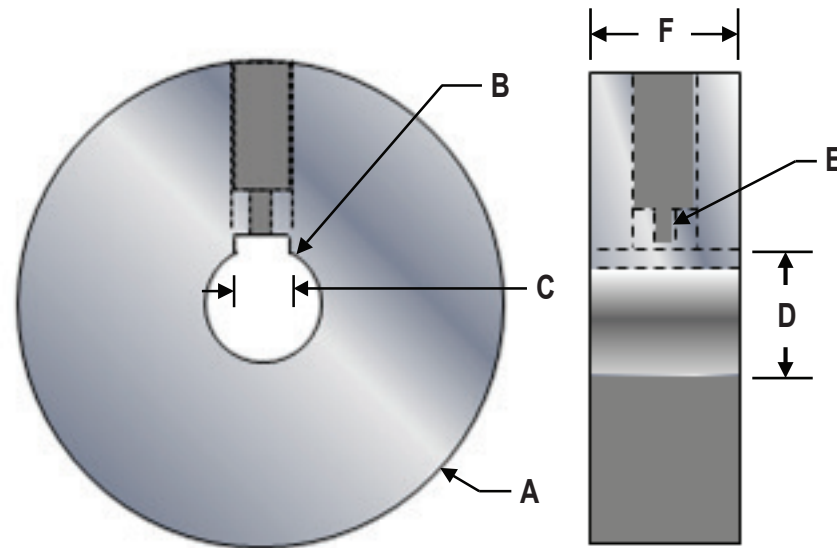

Table 3. Typical dimensions and corresponding tolerances of a timing pulley design

A TSE + 0.0015 (+.050mm) - 0.0000 (-.050mm) (mm)	B BORE + 0.0015 (+.0381mm) - 0.0000 (mm)	C KEYWAY WIDTH + 0.002 (+.050mm) - 0.000 (mm)	D KEYWAY HEIGHT + 0.010 (+.254mm) - 0.000 (mm)	E UNF TAP N/A N/A	F MINIMUM WIDTH + 0.010 (+.254mm) - 0.010 (mm)	F MAXIMUM WIDTH + 0.010 (+.254mm) - 0.010 (mm)
2.000 (50.80)	0.7500 (19.05)	0.188 (4.775)	0.837 (21.259)	1/4 - 28 (M6 x 1.0)	0.250 (6.35)	6.000 (154.40)
3.000 (72.20)	1.0000 (25.40)	0.250 (6.350)	1.114 (28.295)	5/16 - 24 (M8 x 1.25)	0.375 (9.52)	6.000 (154.40)
4.000 (101.60)	1.0000 (25.40)	0.250 (6.350)	1.114 (28.295)	5/16 - 24 (M8 x 1.25)	0.500 (12.70)	6.000 (154.40)
6.000 (154.40)	1.2500 (31.75)	0.313 (7.950)	1.178 (29.921)	3/8 - 24 (M10 x 1.50)	0.500 (12.70)	4.000 (101.60)
8.000 (203.20)	1.2500 (31.75)	0.313 (7.950)	1.178 (29.921)	3/8 - 24 (M10 x 1.50)	0.500 (12.70)	3.000 (72.20)
10.000 (254.60)	1.2500 (31.75)	0.313 (7.950)	1.178 (29.921)	3/8 - 24 (M10 x 1.50)	0.500 (12.70)	2.000 (50.80)
14.000 (355.60)	1.2500 (31.75)	0.313 (7.950)	1.178 (29.921)	3/8 - 24 (M10 x 1.50)	0.500 (12.70)	2.000 (50.80)

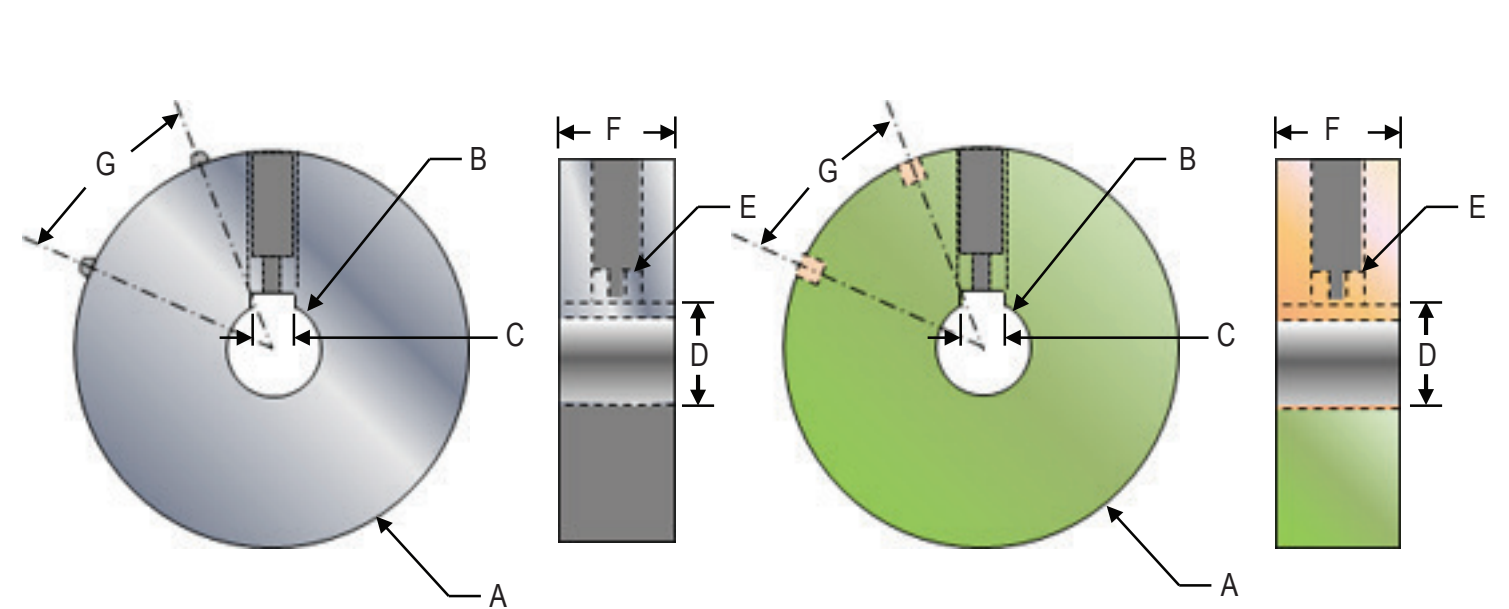
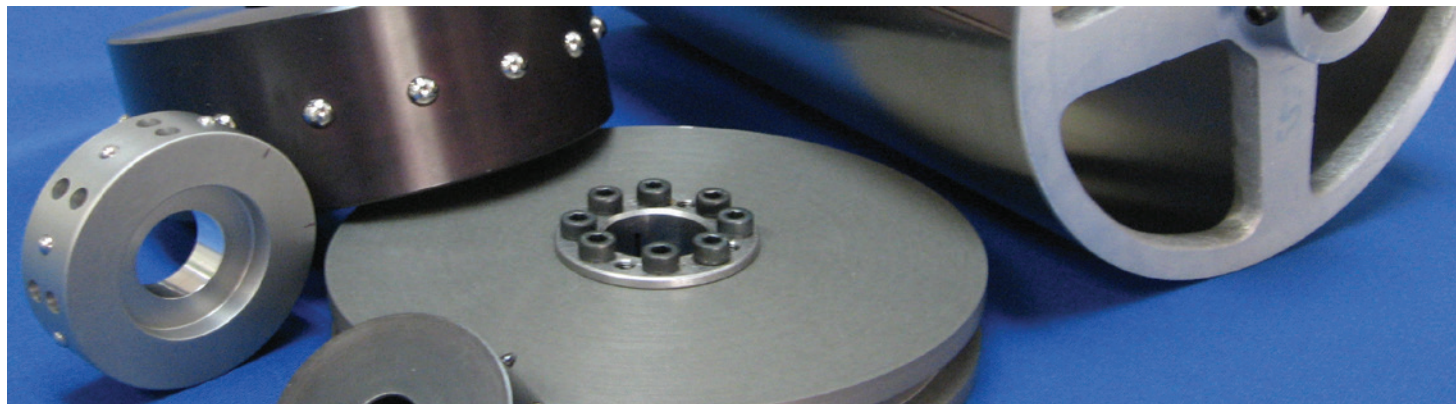

Table 3. typical dimensions and corresponding tolerances of a timing pulley design

A TSD +0.0015 (+.0381mm) -0.0015 (-.0381mm) (mm)	B BORE +0.0015 (+.0381mm) -0.0000 (mm)	C KEYWAY WIDTH +0.002 (+.050mm) -0.000 (mm)	D KEYWAY HEIGHT +0.010 (+.254mm) -0.000 (mm)	E UNF TAP N/A N/A	F MINIMUM WIDTH +0.010 (+.254mm) -0.010 (mm)	F MAXIMUM WIDTH +0.010 (+.254mm) -0.010 (mm)
2.860 (72.644)	1.0000 (25.40)	0.250 (6.35)	1.114 (28.295)	5/16 - 28 (M8 x 1.25)	0.500 (12.700)	6.000 (154.40)
3.815 (96.901)	1.0000 (25.40)	0.250 (6.35)	1.114 (28.295)	5/16 - 24 (M8 x 1.25)	0.500 (12.700)	6.000 (154.40)
5.725 (145.415)	1.2500 (31.75)	0.313 (7.95)	1.178 (29.921)	3/8 - 24 (M10 x 1.50)	0.500 (12.700)	4.000 (101.60)
7.634 (193.904)	1.2500 (31.75)	0.313 (7.95)	1.178 (29.921)	3/8 - 24 (M10 x 1.50)	0.500 (12.700)	3.000 (72.20)
9.544 (242.419)	1.2500 (31.75)	0.313 (7.95)	1.178 (29.921)	3/8 - 24 (M10 x 1.50)	0.500 (12.700)	2.000 (50.80)
10.000 (254.266)	1.2500 (31.75)	0.313 (7.95)	1.178 (29.921)	3/8 - 24 (M10 x 1.50)	0.500 (12.700)	2.000 (50.80)

**TIMING PULLEY DESIGNS**

Belt Technologies' timing pulley design incorporates a pulley body of hard coat anodized aluminum, into which hardened timing components are press fit.

In the Type 1 timing pulley shown above, a hardened tooth press fit into the pulley body engages a perforation in the belt. In a Type II timing pulley a modified drill bushing engages a timing lug on the metal belt.

As a timing pulley diameter must be designed so the belt will be driven at its neutral axis, the illustrative TSD's shown in the table are based on a 1.000" timing pitch and a 0.005" thick belt

As with the friction drive design, a Belt Technologies' timing pulley is manufactured to a 0.002" concentricity. Other critical tolerances in a timing pulley are the radial location tolerance (G) of +/- 10 seconds for both pulley types, and a tooth height tolerance of within 0.003" true position of one another for Type I designs.

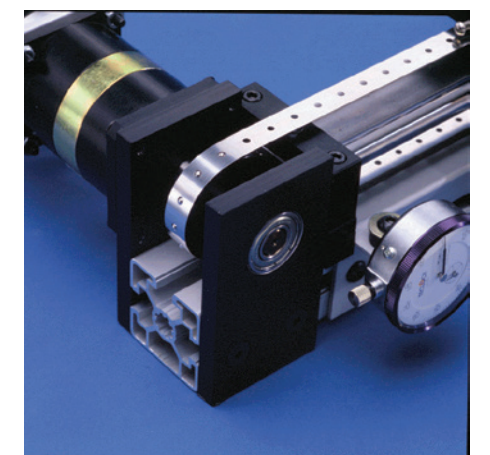



**I-BEAM AND CAPPED TUBE:**

When designing a pulley, the most fundamental consideration is establishing whether it will be used as a friction or timing pulley. Once determined, the Design Engineer then begins to incorporate additional design features best suited to the specific application. If a solid round stock pulley design is incompatible with overall system objectives (primarily the requirement for low rotational inertia due to an aggressive precision position indexing motion profile) the pulley body can be changed to an I-Beam or Capped Tube type construction.

Both types of pulleys are affixed to a shaft via various locking assemblies such as QD® Bushings, Tran-Torque® Collars, Ringfeder® Locking Assemblies, or by the steering collar of Belt Technologies' Independently Steerable Pulley design.

These designs are by nature more complex than those of a solid body pulley, and specific design guidelines are beyond the scope of this document. The drawings shown above will serve as design concepts against which a Belt Technologies Engineer can assist you with the specifics of your application.

**I-Beam With Steering Collar**

Minimum pulley diameter	4.00 (10.16cm)
Minimum face width	3.00 (7.62cm)
Maximum face width	8.00 (20.32cm)

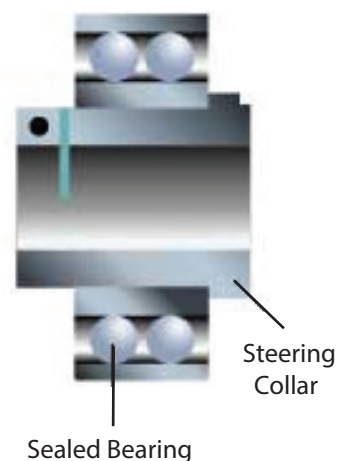
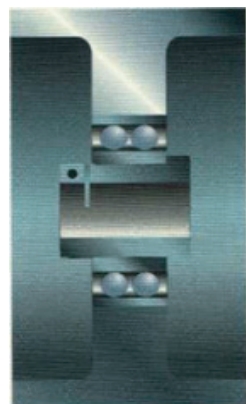

**Capped Tube**

Minimum pulley diameter	4.00 (10.16cm)
Minimum face width	6.00 (15.24cm)

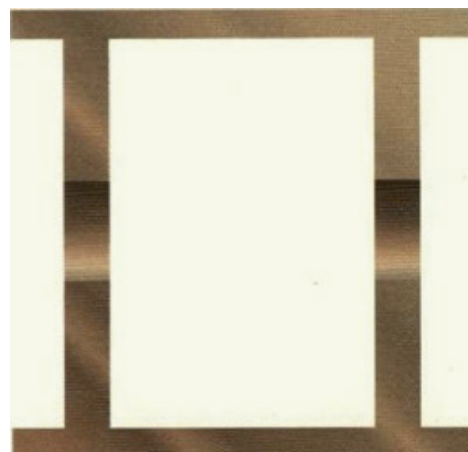
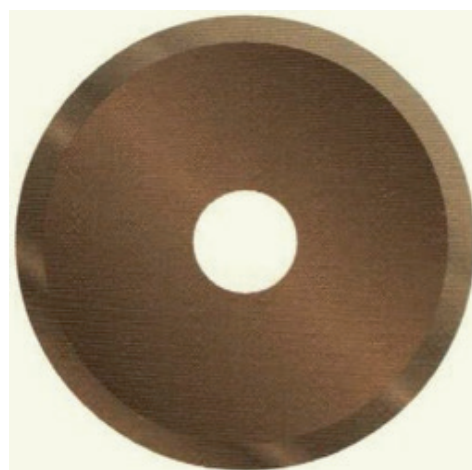

**INDEPENDENTLY STEERABLE PULLEY**

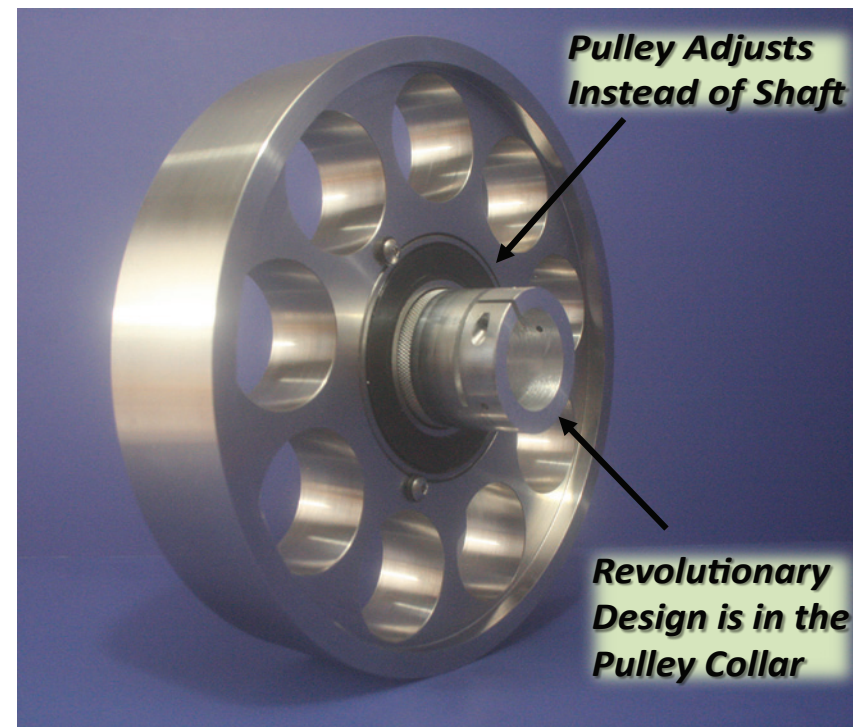

A steering collar-bearing assembly is press fit into the body of a friction drive idler pulley constructed as a solid body or I-Beam. The steering collar serves a dual role in that it is the method by which the pulley is affixed to a shaft, as well as the means by which a belt can be dynamically tracked. For additional details, please refer to Belt Technologies Independently Steerable Pulley New Product Data Sheet.

To assist the Design Engineer in sizing the pulley assembly to the system, the drawing and part tabulation below details overall design dimensions of the steering collar element of the assembly.

Capped Tube pulleys use a variation of this design concept. Please contact a Belt Technologies Engineer for details.

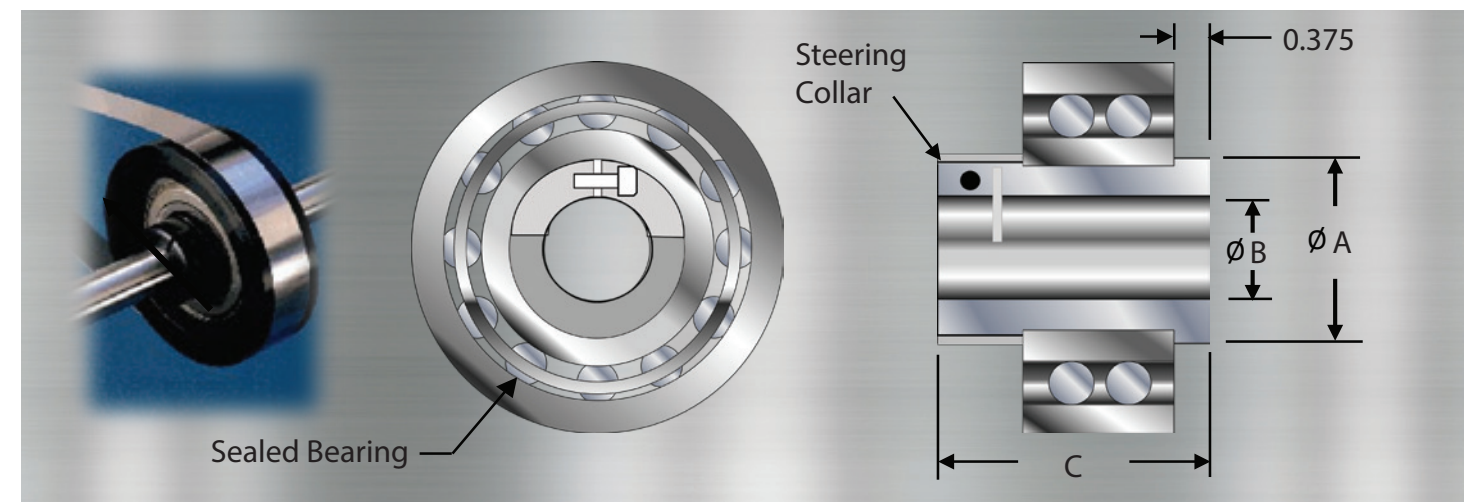

**IN CONCLUSION:**

As with any precision technology, idiosyncrasies in both the design and manufacture of friction and timing pulleys for metal belts requires design experience and manufacturing expertise. Belt Technologies invites you to use this document for Metal Belt and Pulley designs, then contact one of our Applications Sales Engineers to assure a successful plan is in place for your project.

	A	B +0.001 (+.025mm) -0.000	C
-1	1.20 (30.48)	.500 (12.70)	1.956 (49.682)
-2	1.50 (38.10)	.750 (19.05)	2.331 (59.207)
-3	2.50 (63.50)	1.000 (25.40)	2.393 (60.782)
-4	2.50 (63.50)	1.250 (31.75)	2.893 (73.482)
-5	3.00 (76.20)	1.500 (38.10)	3.456 (87.782)

(mm)





We hope this introduction to metal belt technology provided you with an understanding of important design considerations and helped you qualify your application. Our unique metal belt technology has resulted in a wide range of solutions for a long and growing list of satisfied customers. We will provide a list of these companies at your request.

*Should you require further assistance and design review, please contact a Belt Technologies engineer by telephone, fax or e-mail.*

*Please fax the design checklist from the facing page with your application information. Thank you for your interest in Belt Technologies.*

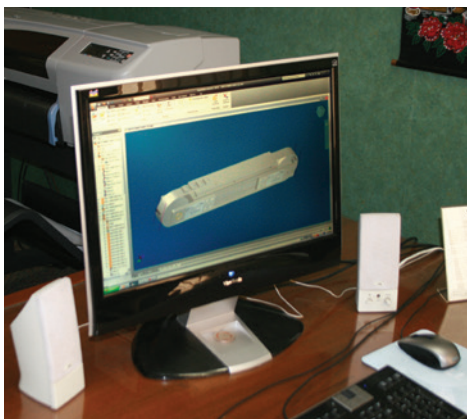

## STEEL BELT DESIGN CHECKLIST

Use additional sheets for further information, if appropriate

**In the U.K., Europe & the Pacific Rim:**

**In the Americas:**

Belt Technologies Europe  
3rd Floor, Pennine House  
Washington  
Tyne and Wear NE37 1LY  
United Kingdom  
Tel: +44 (0)191-415-3010  
Fax: +44 (0)191-415-0333  
E-Mail: [sales@bte.co.uk](mailto:sales@bte.co.uk)  
[www.belttechnologies.co.uk](http://www.belttechnologies.co.uk)

Belt Technologies, Inc.  
Corporate Headquarters  
11 Bowles Road  
Agawam, MA 01001  
USA  
Tel: (413) 786-9922  
Fax: (413) 789-2786  
E-Mail: [engineer@belttechnologies.com](mailto:engineer@belttechnologies.com)  
[www.belttechnologies.com](http://www.belttechnologies.com)

FROM: \_\_\_\_\_ (Name)  
 \_\_\_\_\_ (Company)  
 \_\_\_\_\_ (Address)  
 \_\_\_\_\_  
 \_\_\_\_\_ (Tel/ Fax)

1. Use:      CONVEY      INDEX      TIME      POSITION      POWER TRANSMISSION  
                                                                 

2. Size Considerations:

Belt Width \_\_\_\_\_ Pulley Diameter \_\_\_\_\_  
 Number of Pulleys \_\_\_\_\_ Pulley Centers \_\_\_\_\_

3. Loading:

Belt Speed \_\_\_\_\_ Max Drive Torque \_\_\_\_\_  
 Acceleration \_\_\_\_\_ Static Load \_\_\_\_\_

4. Desired Belt Characteristics:

Strength      Precision      Cleanliness      Corrosion Resistance      Thermal Conductance  
                                                  
 High Temperature \_\_\_\_\_ °C     °F

5. Quantities: Number of Belts to be quoted \_\_\_\_\_ Number of Pulleys to be quoted \_\_\_\_\_

6. Please Include a diagram of your system.





### In the Americas:

Belt Technologies, Inc.  
Corporate Headquarters  
11 Bowles Road  
Agawam, MA 01001  
USA  
Tel: (413) 786-9922  
Fax: (413) 789-2786  
E-Mail: [engineer@belttechnologies.com](mailto:engineer@belttechnologies.com)  
[www.belttechnologies.com](http://www.belttechnologies.com)

### In the U.K., Europe & the Pacific Rim:

Belt Technologies Europe  
3rd Floor • Pennine House  
Washington  
Tyne and Wear NE37 1LY  
United Kingdom  
Tel: +44(0)191-415-3010  
Fax: +44(0)191-415-0333  
E-Mail: [sales@bte.co.uk](mailto:sales@bte.co.uk)  
[www.belttechnologies.co.uk](http://www.belttechnologies.co.uk)